

TASCAM

TEAC Professional Division

9101429501

CD-302

Dual CD Player

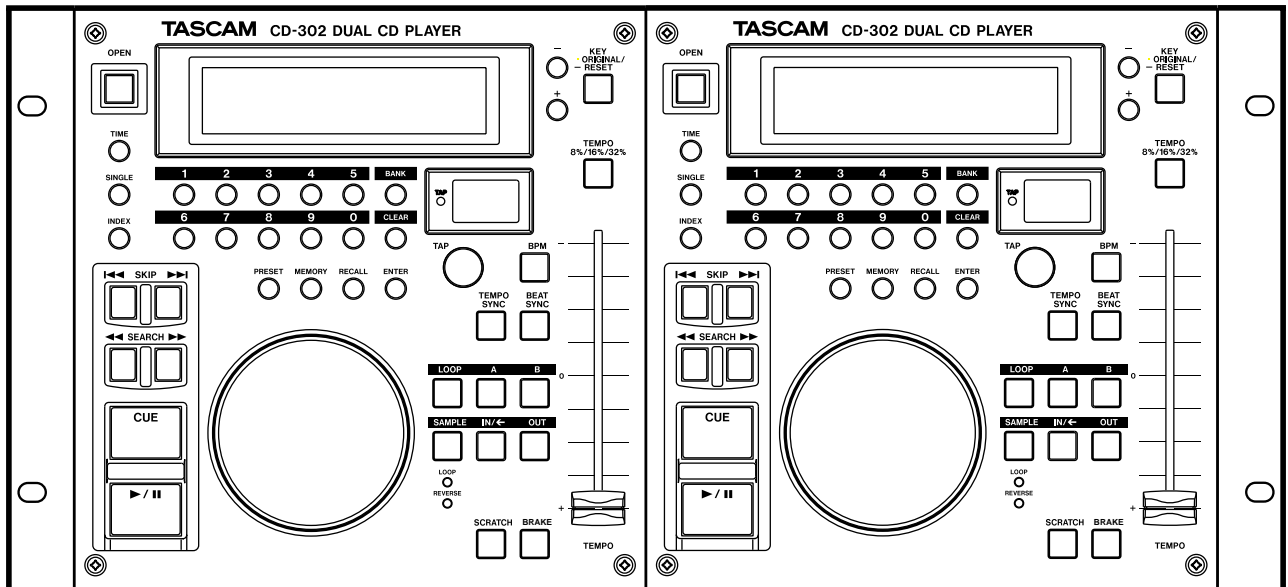

OWNER'S MANUAL



CAUTION
RISK OF ELECTRIC SHOCK
DO NOT OPEN



CAUTION: TO REDUCE THE RISK OF ELECTRIC SHOCK, DO NOT REMOVE COVER (OR BACK). NO USER-SERVICEABLE PARTS INSIDE. REFER SERVICING TO QUALIFIED SERVICE PERSONNEL.



The lightning flash with arrowhead symbol, within an equilateral triangle, is intended to alert the user to the presence of uninsulated "dangerous voltage" within the product's enclosure that may be of sufficient magnitude to constitute a risk of electric shock to persons..



The exclamation point within an equilateral triangle is intended to alert the user to the presence of important operating and maintenance (servicing) instructions in the literature accompanying the appliance.

This appliance has a serial number located on the rear panel. Please record the model number and serial number and retain them for your records.
Model number _____
Serial number _____

WARNING: TO PREVENT FIRE OR SHOCK HAZARD, DO NOT EXPOSE THIS APPLIANCE TO RAIN OR MOISTURE.

Important Safety Precautions

Note for U.K. Customers

DO NOT cut off the mains plug from this equipment.

If the plug fitted is not suitable for the power points in your home or the cable is too short to reach a power point, then obtain an appropriate safety approved extension lead or consult your dealer.

If nonetheless the mains plug is cut off, remove the fuse and dispose of the plug immediately, to avoid a possible shock hazard by inadvertent connection to the mains supply.

If this product is not provided with a mains plug, or one has to be fitted, then follow the instructions given below:

IMPORTANT: DO NOT make any connection to the larger terminal which is marked with the letter E or by the safety earth symbol \perp or coloured GREEN or GREEN-and-YELLOW.

The wires in the mains lead on this product are coloured in accordance with the following code:

BLUE : **NEUTRAL**
BROWN : **LIVE**

As these colours may not correspond with the coloured markings identifying the terminals in your plug proceed as follows:

The wire which is coloured BLUE must be connected to the terminal which is marked with the letter N or coloured BLACK.

The wire which is coloured BROWN must be connected to the terminal which is marked with the letter L or coloured RED.

When replacing the fuse only a correctly rated approved type should be used and be sure to re-fit the fuse cover.

IF IN DOUBT — CONSULT A COMPETENT ELECTRICIAN.

For U.S.A

TO THE USER

This equipment has been tested and found to comply with the limits for a Class A digital device, pursuant to Part 15 of the FCC Rules. These limits are designed to provide reasonable protection against harmful interference when the equipment is operated in a commercial environment. This equipment generates, uses, and can radiate radio frequency energy and, if not installed and used in accordance with the instruction manual, may cause harmful interference to radio communications.

Operation of this equipment in a residential area is likely to cause harmful interference in which case the user will be required to correct the interference at his own expense.

CAUTION

Changes or modifications to this equipment not expressly approved by TEAC CORPORATION for compliance could void the user's authority to operate this equipment.

IMPORTANT SAFETY INSTRUCTIONS

CAUTION:

- Read all of these Instructions.
- Save these Instructions for later use.
- Follow all Warnings and Instructions marked on the audio equipment.

- 1) Read Instructions** — All the safety and operating instructions should be read before the product is operated.
- 2) Retain Instructions** — The safety and operating instructions should be retained for future reference.
- 3) Heed Warnings** — All warnings on the product and in the operating instructions should be adhered to.
- 4) Follow Instructions** — All operating and use instructions should be followed.
- 5) Cleaning** — Unplug this product from the wall outlet before cleaning. Do not use liquid cleaners or aerosol cleaners. Use a damp cloth for cleaning.
- 6) Attachments** — Do not use attachments not recommended by the product manufacturer as they may cause hazards.
- 7) Water and Moisture** — Do not use this product near water — for example, near a bath tub, wash bowl, kitchen sink, or laundry tub; in a wet basement; or near a swimming pool; and the like.
- 8) Accessories** — Do not place this product on an unstable cart, stand, tripod, bracket, or table. The product may fall, causing serious injury to a child or adult, and serious damage to the product. Use only with a cart, stand, tripod, bracket, or table recommended by the manufacturer, or sold with the product. Any mounting of the product should follow the manufacturer's instructions, and should use a mounting accessory recommended by the manufacturer.
- 9) A product and cart combination should be moved with care.** Quick stops, excessive force, and uneven surfaces may cause the product and cart combination to overturn.



- 10) Ventilation** — Slots and openings in the cabinet are provided for ventilation and to ensure reliable operation of the product and to protect it from overheating, and these openings must not be blocked or covered. The openings should never be blocked by placing the product on a bed, sofa, rug, or other similar surface. This product should not be placed in a built-in installation such as a bookcase or rack unless proper ventilation is provided or the manufacturer's instructions have been adhered to.
- 11) Power Sources** — This product should be operated only from the type of power source indicated on the marking label. If you are not sure of the type of power supply to your home, consult your product dealer or local power company. For products intended to operate from battery power, or other sources, refer to the operating instructions.
- 12) Grounding or Polarization** — This product may be equipped with a polarized alternating-current line plug (a plug having one blade wider than the other). This plug will fit into the power outlet only one way. This is a safety feature. If you are unable to insert the plug fully into the outlet, try reversing the plug. If the plug should still fail to fit, contact your electrician to replace your obsolete outlet. Do not defeat the safety purpose of the polarized plug.
- 13) Power-Cord Protection** — Power-supply cords should be routed so that they are not likely to be walked on or pinched by items placed upon or against them, paying particular attention to cords at plugs, convenience receptacles, and the point where they exit from the product.
- 14) Outdoor Antenna Grounding** — If an outside antenna or cable system is connected to the product, be sure the antenna or cable system is grounded so as to provide some protection against voltage surges and built-up static charges. Article 810 of the National Electrical Code, ANSI/NFPA 70, provides information with regard to proper grounding of the mast and supporting structure, grounding of the lead-in wire to an antenna discharge unit, size of grounding conductors, location of antenna-discharge unit, connection to grounding electrodes, and requirements for the grounding electrode.

"Note to CATV system installer:

This reminder is provided to call the CATV system installer's attention to Section 820-40 of the NEC which provides guidelines for proper grounding and, in particular, specifies that the cable ground shall be connected to the grounding system of the building, as close to the point of cable entry as practical.

Example of Antenna Grounding as per National Electrical Code, ANSI/NFPA 70

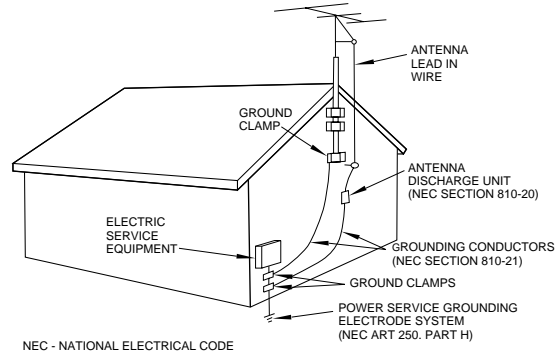

- 15) Lightning** — For added protection for this product during a lightning storm, or when it is left unattended and unused for long periods of time, unplug it from the wall outlet and disconnect the antenna or cable system. This will prevent damage to the product due to lightning and power-line surges.
- 16) Power Lines** — An outside antenna system should not be located in the vicinity of overhead power lines or other electric light or power circuits, or where it can fall into such power lines or circuits. When installing an outside antenna system, extreme care should be taken to keep from touching such power lines or circuits as contact with them might be fatal.
- 17) Overloading** — Do not overload wall outlets, extension cords, or integral convenience receptacles as this can result in risk of fire or electric shock.
- 18) Object and Liquid Entry** — Never push objects of any kind into this product through openings as they may touch dangerous voltage points or short-out parts that could result in a fire or electric shock. Never spill liquid of any kind on the product.
- 19) Servicing** — Do not attempt to service this product yourself as opening or removing covers may expose you to dangerous voltage or other hazards. Refer all servicing to qualified service personnel.
- 20) Damage Requiring Service** — Unplug this product from the wall outlet and refer servicing to qualified service personnel under the following conditions:
 - a) when the power-supply cord or plug is damaged.
 - b) if liquid has been spilled, or objects have fallen into the product.
 - c) if the product has been exposed to rain or water.
 - d) if the product does not operate normally by following the operating instructions. Adjust only those controls that are covered by the operating instructions as an improper adjustment of other controls may result in damage and will often require extensive work by a qualified technician to restore the product to its normal operation.
 - e) if the product has been dropped or damaged in any way.
 - f) when the product exhibits a distinct change in performance — this indicates a need for service.
- 21) Replacement Parts** — When replacement parts are required, be sure the service technician has used replacement parts specified by the manufacturer or have the same characteristics as the original part. Unauthorized substitutions may result in fire, electric shock, or other hazards.
- 22) Safety Check** — Upon completion of any service or repairs to this product, ask the service technician to perform safety checks to determine that the product is in proper operating condition.
- 23) Wall or Ceiling Mounting** — The product should be mounted to a wall or ceiling only as recommended by the manufacturer.
- 24) Heat** — The product should be situated away from heat sources such as radiators, heat registers, stoves, or other products (including amplifiers) that produce heat.

SAFETY INFORMATION

This product has been designed and manufactured according to FDA regulations "title 21, CFR, chapter 1, subchapter J, based on the Radiation Control for Health and Safety Act of 1968", and is classified as a class 1 laser product. There is no hazardous invisible laser radiation during operation because invisible laser radiation emitted inside of this product is completely confined in the protective housings.

The label required in this regulation is shown ①.

CAUTION

- DO NOT REMOVE THE PROTECTIVE HOUSING USING A SCREWDRIVER.
- USE OF CONTROLS OR ADJUSTMENTS OR PERFORMANCE OF PROCEDURES OTHER THAN THOSE SPECIFIED HEREIN MAY RESULT IN HAZARDOUS RADIATION EXPOSURE.
- IF THIS PRODUCT DEVELOPS TROUBLE, CONTACT YOUR NEAREST QUALIFIED SERVICE PERSONNEL, AND DO NOT USE THE PRODUCT IN ITS DAMAGED STATE.

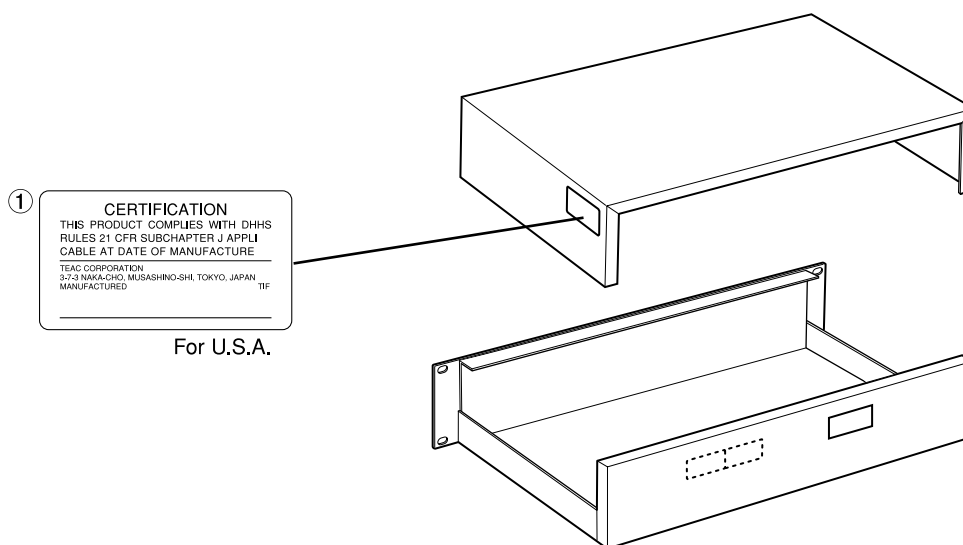

Optical pickup: Type : KSS-213C
Manufacturer : SONY Corporation
Laser output : Less than 0.4 mW on the objective lens
Wavelength : 760_800nm

For CANADA

AC POWER CORD CONNECTION

CAUTION:
TO PREVENT ELECTRIC SHOCK, MATCH WIDE BLADE OF
PLUG TO WIDE SLOT, FULLY INSERT.

Pour le CANADA

CORDE DE CONNEXION CA

ATTENTION:
POUR ÉVITER LES CHOCS ÉLECTRIQUES, INTRODUIRE LA
LAME LA PLUS LARGE DE LA FICHE DANS LA BORNE
CORRESPONDANTE DE LA PRISE ET POUSSER JUSQU'AU
FOND.

1 - Before you start

1.1	Main features	7
1.2	Environmental conditions	7
1.2.1	Beware of condensation	8
1.2.2	Never use a stabilizer	8
1.2.3	Handling of discs	8
1.3	Backup memory	8
1.4	Anti-shock memory	8
1.5	Instant start	8
1.6	Preset functions	9
1.7	Preset functions	9
1.8	Displayed characters	10

2 - Front and rear panels

2.1	Main unit (front panel)	12
①	POWER switch and indicator	12
②	OPEN keys (1 and 2)	12
③	Disc trays	12
2.2	Main unit (rear panel)	12
④	OUTPUT jacks	12
⑤	REMOTE connectors	12
⑥	FADER START/STOP, EVENT START jacks	12
2.3	Remote control unit (front panel) ...	12
⑦	OPEN key	12
⑧	TIME key	12
⑨	SINGLE key	12
⑩	INDEX key	12
⑪	SKIP keys	12
⑫	SEARCH keys	12
⑬	CUE key	13
⑭	PLAY/PAUSE key	13
⑮	JOG dial	13
⑯	Number keys and CLEAR key	13
⑰	BANK key	13
⑱	PRESET key	13
⑲	MEMORY key	13
⑳	RECALL key	13
㉑	ENTER key	13
㉒	BPM counter	13
㉓	TAP key	13
㉔	BPM key	13
㉕	TEMPO SYNC key	13
㉖	BEAT SYNC key	13
㉗	LOOP key	13
㉘	A and B keys	14
㉙	SAMPLE key	14
㉚	IN/OUT keys	14
㉛	SCRATCH key	14
㉜	BRAKE key	14
㉝	+ and - keys	14
㉞	KEY ORIGINAL/RESET key	14
㉟	TEMPO 8%/16%/32% key	14
㊱	TEMPO slider	14
2.4	Remote control unit (rear)	14
㊲	REMOTE connectors	14

2.5	Display	15
㊳	TRACK indicator	15
㊴	Bank indicators	15
㊵	Loop mode indicator	15
㊶	REMAIN indicator	15
㊷	M (memory) indicator	15
㊸	SINGLE indicator	15
㊹	PROGRAM indicator	15
㊺	Time display	15
㊻	Time address bar	15
㊼	TEMPO indicator	15
㊽	KEY indicator	15
㊾	INDEX indicator	15
㊿	INCR indicator	15
①	AUTO READY Indicator	15
②	RELAY Indicator	15
③	AUTO CUE Indicator	15

3 - Basic operations

3.1	Playback operations	16
3.1.1	Playback	16
3.1.2	Pause	16
3.1.3	Stop	16
3.2	Play modes	16
3.2.1	Cross-play	16
3.3	Cueing	16
3.3.1	CUE	16
3.3.2	Auto Cue	17
3.3.3	Cueing using the JOG dial	17
3.3.4	Cueing using the SEARCH keys	17
3.3.5	Cueing using the numeric keys	17
3.4	Loop play	17
3.4.1	Selecting the loop mode	17
3.4.2	A-B loop play mode	18
3.4.3	Setting A-B loop points	18
3.4.4	Playback in A-B loop play mode	18
3.4.5	Clearing loop points	18
3.4.6	Editing the loop points	18
3.4.7	A-B loop duration	18
3.4.8	SINGLE loop	19
3.4.9	ALL loop	19

4 - Advanced Operations

4.1	Tempo (speed) control	20
4.1.1	Changing only tempo (speed)	20
4.2	Key (pitch) control	20
4.2.1	Controlling the key change as a percentage	20
4.2.2	Controlling the key change in semitone steps	20
4.3	Sampling	20
4.3.1	Sampling	21
4.3.2	Using the A-B loop as a sample source	21
4.3.3	Editing the OUT point	21
4.3.4	Playback of sampled data	21
4.3.5	Playback of sampled data in reverse	21

TASCAM CD-302 — Table of Contents

4.3.6	Setting the sampled data playback tempo	21	4.11	Voice Reduce function	26
4.3.7	Setting the sampled data playback key	22	4.12	Programmed playback	26
4.3.8	Looped playback of sampled data	22	4.12.1	Setting the program steps	26
4.3.9	Clearing the sampled data	22	4.12.2	Adding tracks to the middle of a program	26
4.4	Bend function	22	4.12.3	Deleting program steps	27
4.5	BPM	22	4.12.4	Deleting a whole program	27
4.5.1	BPM counter	22	4.13	Output level	27
4.5.2	Clearing the BPM	22	4.14	Brake function	27
4.5.3	Using the tap mode with the BPM counter	22	4.15	Setting the EOM time	28
4.5.4	Clearing the BPM counter (tap)	22	4.16	Auto Ready	28
4.5.5	Editing the BPM (tap) using the dial	22	4.17	Timer Play	28
4.6	Number key modes	23	4.18	Incremental Play	28
4.7	Tempo Sync	23	4.19	Relay Play	29
4.7.1	Cancellation of tempo sync	23	4.20	Direct mode	29
4.8	Beat Sync	23	4.21	Disc Tray Auto Close	29
4.8.1	Cancellation of beat sync	24	4.22	Sleep	29
4.9	Scratch	24	4.23	Fader and Event Start/Stop	30
4.10	Memories	24	4.24	Factory Preset	30
4.10.1	Storing a memory	25	5 - Specifications and reference		
4.10.2	Recalling a memory	25	5.1	Specifications	31
4.10.3	Recalling a memory from a track number	25	5.1.1	Dimensions	31
4.10.4	Overwriting a memory	25	5.2	Error messages, etc.	32
4.10.5	Memory recall (sample points)	25	5.2.1	Spare parts	32
4.10.6	Clearing memories	26			

1.1 Main features

- Two high-quality precision CD decks in a single rack-mountable unit.
- RCA unbalanced outputs for each deck
- Dedicated per-deck remote control units (detachable and rack-mountable)
- 10 seconds of anti-shock memory per deck.
- Instant start
- Large jog dial for frame-accurate cue point searching
- Selectable tempo and key control range : $\pm 8\%$, $\pm 16\%$, or $\pm 32\%$ (or disabled).
- Key control function allows changing key without affecting the original tempo
- Key control mode in percentage or semitone steps
- Original Key function allows tempo change while maintaining the original key
- Pitch control to change both tempo and key
- 100 mm tempo slider
- 10 seconds' sampling function (per deck)
- 3-way loop functions: A-B, SINGLE, and ALL
- Seamless loop function in A-B loop
- Automatic BPM (beats per minute) count function and BPM counter
- Tempo sync between the decks
- Beat sync between the decks
- TAP function for manual BPM settings
- Bend function allows adjusting of beats manually between the two decks
- Brake function allows braking in exactly the same way as on a record turntable
- Scratch function allows scratch play
- Voice Reduce function lowers the level of the vocal part
- Up to 1,000 track memories. Tracks can be memorized in 5 banks (200 tracks each, Bank A to E)
- Up to 24 parameters can be set as user-definable memory functions (various settings)
- Output level control in the digital domain (± 6 dB, in 1.0 dB steps).
- Selectable Elapsed and Song Remain time display
- Continuous play
- Single play
- Program play
- Auto cue function (-72 , -66 , -60 , -54 , or -35 dB)
- Auto ready function to cue up following tracks
- End of Message function (10, 15, 20, 30, 60, or 90 seconds).
- Timer play for deck 1 followed by deck 2.
- Relay play allows consecutive playback using both decks (as one deck stops, the other can be set to start automatically).
- Sleep function (automatic shutdown of the deck after 30 minutes of inactivity)
- Tray auto close function can close the tray automatically one minute after the tray is opened
- Incremental play
- Event start
- Fader start

1.2 Environmental conditions

The TASCAM CD-302 may be used in most areas, but to maintain top performance, and prolong operating life, observe the following environmental conditions:

The nominal temperature should be between 5°C and 35°C (41°F and 95°F).

Relative humidity should be 30 to 90 degrees non-condensing.

Make sure that the drive unit is mounted in a level position for correct operation.

The units should be mounted, using the supplied rack mounting kits. A typical configuration is shown below, but other configurations are possible:

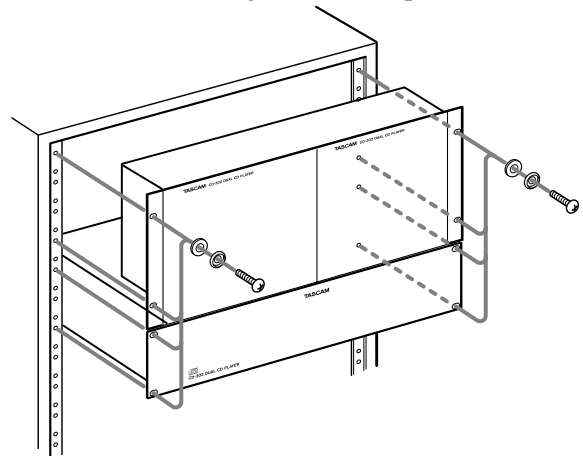

NOTE

If the disc trays are more than 5 degrees away from the horizontal, they will not open or close.

1 • Before you start—Backup memory

1.2.1 Beware of condensation

If the player (or a compact disc) is moved from a cold to a warm place, or used after a sudden temperature change, there is a danger of condensation; vapor in the air could condense on the internal mechanism, making correct operation impossible. To prevent this, or if this occurs, leave the player for one or two hours with the power turned on, then turn the power off and on again.

1.2.2 Never use a stabilizer

The TASCAM CD-302 has a stabilizer disc built into its drive mechanisms. Using commercially available CD stabilizers with this player will damage the mechanisms and cause them to malfunction.

NOTE

Never use a disc that has had a stabilizer mounted to it. The residual adhesive may cause the disc to stick to the mechanism of the TASCAM CD-302. If it sticks to the mechanism, you will need a technician to get it out.

1.2.3 Handling of discs

The unit has been designed specifically for reproduction of discs bearing the  mark. No other discs can be reproduced.

Observe the following:

- Always place the compact discs in the trays with their label facing upward (compact discs can only be played on one side).
- To remove a disc from its storage case, press down on the center of the case, and lift the disc out, holding it carefully by the edges.



- Finger marks and dust should be carefully wiped off the disc's recorded surface with a soft cloth. Unlike conventional records, the compact disc has no grooves to collect dust and microscopic debris, so gently wiping with a soft cloth should remove most particles.



- Wipe in a straight motion from the inside to the outside of the disc. Small dust particles and light stains will have absolutely no effect on reproduction quality.
- Never use such chemicals as record sprays, anti-static sprays or fluid, benzine or thinner to clean compact discs. Such chemicals will do irreparable damage to the disc's plastic surface.
- Discs should be returned to their cases after use to avoid serious scratches that could cause the laser pickup to "skip".
- Don't expose discs to direct sunlight or high humidity and temperature for extended periods. Long exposure to high temperature can warp the disc.
- Only use circular compact discs. Avoid using non-circular promotional, etc. discs.

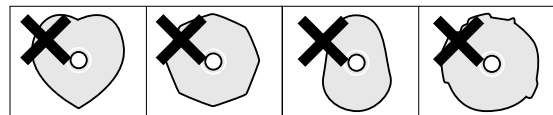

- To keep the laser pickups clean, don't touch them. For the same reason, don't leave the disc trays open unnecessarily.

1.3 Backup memory

Each time you turn off the power, the status of the following features are stored into back up memory.

- Playback mode (Continue, Single, Program)
- Time mode (Elapsed, remain)
- Preset functions
- Contents of Program
- BANKs A through E
- TEMPO key ((%, 16%, 32%)
- INDEX (on/off)
- LOOP (on/off)

1.4 Anti-shock memory

The CD-302 provides 10 seconds' worth of anti-shock memory for each deck.

1.5 Instant start

The CD-302 will start playing from pause mode immediately when the **PLAY** key is pressed, due to the antishock memory function.

1.6 Preset functions

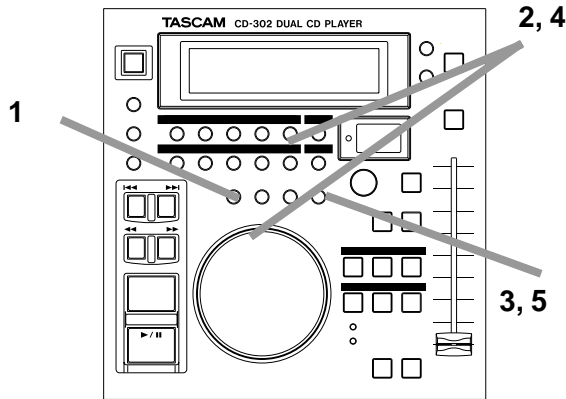

- 1 Press the PRESET key ⑬.
- 2 Select the name and number of the preset function you want to set, with the JOG dial ⑮ or the number keys ⑯.
- 3 Press the ENTER key ⑳.
- 4 Set the function value using the JOG dial ⑮.
- 5 Press the ENTER key ⑳ to confirm the entry.

The way in which the parameters of the preset functions listed in 1.7, “Preset functions” are set is described here:

1.7 Preset functions

No.	Display	Description and explanation	Default setting
01	LOOP	Loop mode (3.4, “Loop play”)	A-B
02	CUE_P	Cue point (3.3, “Cueing”)	PLY
03	JOG	Jog dial resolution (3.3.3, “Cueing using the JOG dial”)	36
04	KEY	Key change mode (4.2, “Key (pitch) control”)	+
05	SAMP_P	Sample playback direction (4.3.5, “Playback of sampled data in reverse”)	F
06	SAMP_L	Sample playback loop (4.3.8, “Looped playback of sampled data”)	OFF
07	SAMP_T	Sample playback tempo (4.3.6, “Setting the sampled data playback tempo”)	0.0
08	SAMP_K	Sample playback key (4.3.7, “Setting the sampled data playback key”)	0.0
09	SAMP_R	Sample points recalled with memory (4.10.5, “Memory recall (sample points)”)	OFF
10	VOICE_R	Voice Reduce function (4.11, “Voice Reduce function”)	OFF
11	PROG	Program setup and editing (4.12, “Programmed playback”)	
12	OUTPUT	Output level (4.13, “Output level”)	NOR
13	BRAKE	Braking time (4.14, “Brake function”)	1.6
14	EOM	EOM Time (4.15, “Setting the EOM time”)	OFF
15	A_CUE	Auto Cue (3.3.2, “Auto Cue”)	-72
16	A_REDY	Auto Ready (4.16, “Auto Ready”)	OFF
17	T_PLAY	Timer Play (4.17, “Timer Play”)	OFF

1 • Before you start—Displayed characters

No.	Display	Description and explanation	Default setting
18	<i>I_PLAY</i> I_PLAY	Incremental Play (4.18, "Incremental Play")	OFF
19	<i>r_PLAY</i> R_PLAY	Relay Play (4.19, "Relay Play")	OFF
20	<i>dIrEcT</i> DIRECT	Direct mode (4.20, "Direct mode")	OFF
21	<i>cLOSE</i> CLOSE	Disc Tray auto close (4.21, "Disc Tray Auto Close")	ON
22	<i>SLEEP</i> SLEEP	Sleep mode (4.22, "Sleep")	ON
23	<i>F_PrE</i> F_PRE	Factory settings (4.24, "Factory Preset")	
24	<i>ALL_cL</i> ALL_CL	Clear all memories (4.10.6, "Clearing memories")	

1.8 Displayed characters

The characters on the CD-302 display are shown as in the table below:

A	B	C	D	E	F	G	H	I	J	K	L
<i>A</i>	<i>b</i>	<i>c</i>	<i>d</i>	<i>E</i>	<i>F</i>	<i>G</i>	<i>H</i>	<i>I</i>	<i>J</i>	<i>K</i>	<i>L</i>
M	N	O	P	Q	R	S	T	U	V	W	X
<i>m</i>	<i>n</i>	<i>O</i>	<i>P</i>	<i>q</i>	<i>r</i>	<i>S</i>	<i>t</i>	<i>U</i>	<i>v</i>	<i>W</i>	<i>x</i>
Y	Z	0	1	2	3	4	5	6	7	8	9
<i>y</i>	<i>Z</i>	<i>0</i>	<i>1</i>	<i>2</i>	<i>3</i>	<i>4</i>	<i>5</i>	<i>6</i>	<i>7</i>	<i>8</i>	<i>9</i>

2 - Front and rear panels

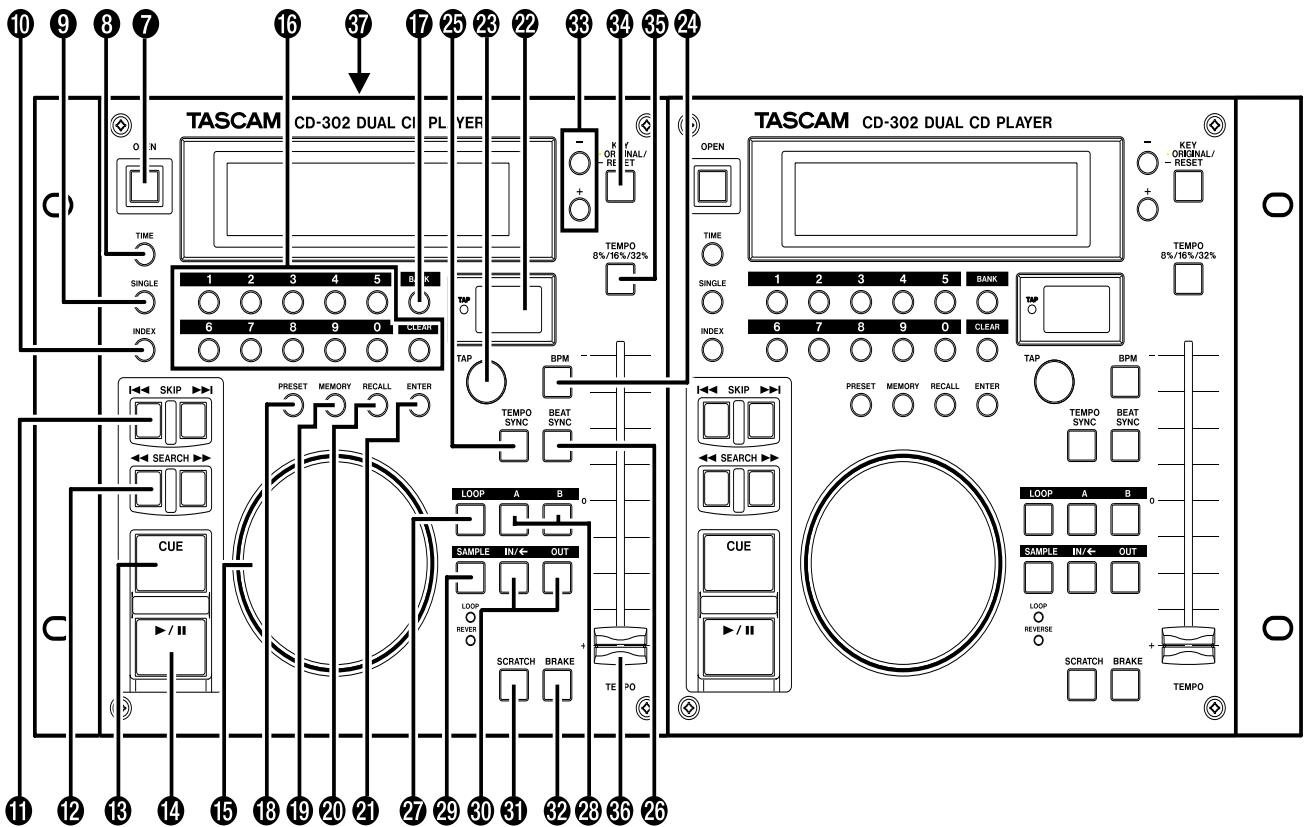
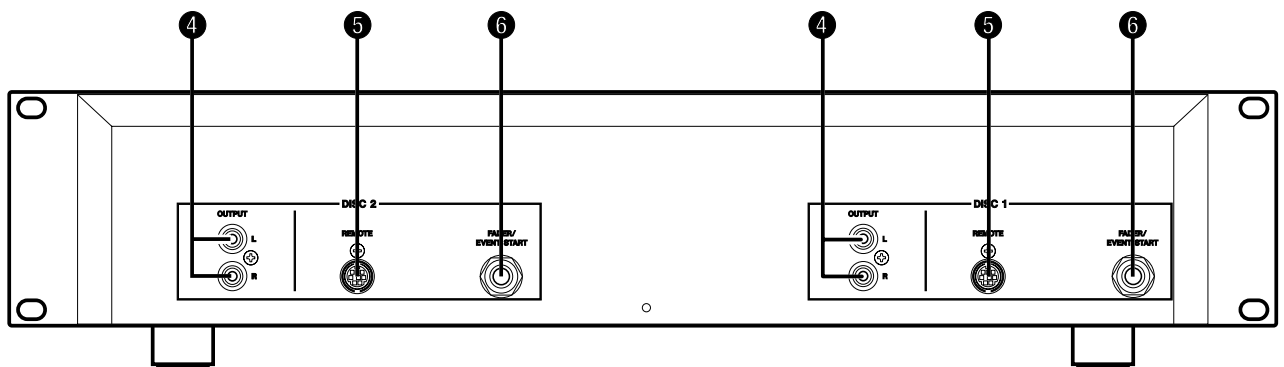
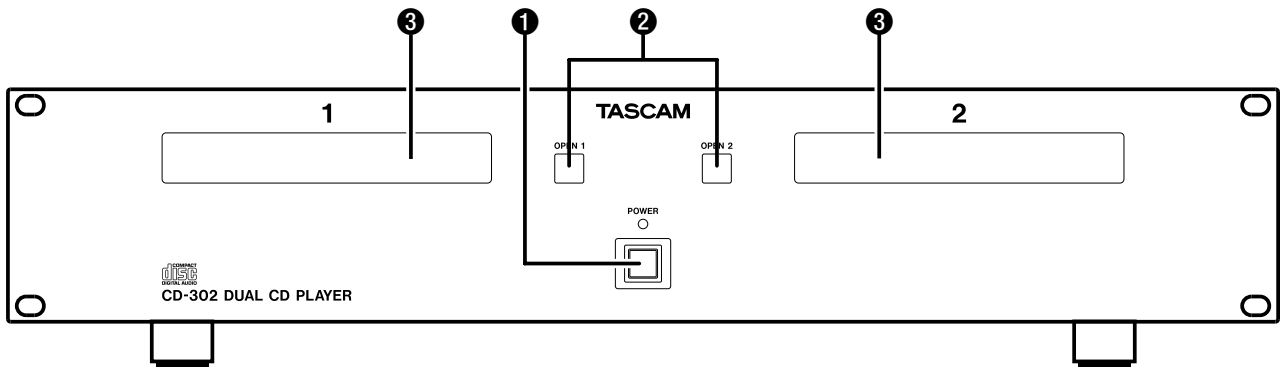

2 • Front and rear panels—Main unit (front panel)

2.1 Main unit (front panel)

Since you perform almost all control functions of the CD-302 from the remote control unit, the front panel only contains the following features:

❶ POWER switch and indicator

Turns the power on and off. The indicator lights when power is supplied.

When Direct Mode (see 4.20, “Direct mode”) is on, the drive starts playing when power is supplied.

❷ OPEN keys (1 and 2)

Open and close the appropriate disc tray.

NOTE

These keys cannot be used when the Direct mode (see 4.20, “Direct mode”) is off and a disc is being played back.

❸ Disc trays

Insert Compact Discs into these trays, label side upwards.

2.2 Main unit (rear panel)

❹ OUTPUT jacks

RCA connectors providing line level output signals.

❺ REMOTE connectors

Use these connectors to connect the remote control units.

❻ FADER START/STOP, EVENT START jacks

The decks can be controlled using external Fader Start and Event Start commands through these jacks. Connect appropriately-wired tip-ring-sleeve plugs to these jacks.

See 4.23, “Fader and Event Start/Stop” for details of how to wire the plugs, and how to use these connectors.

2.3 Remote control unit (front panel)

❼ OPEN key

Opens and closes the disc tray.

NOTE

This key cannot be used when the Direct mode (see 4.20, “Direct mode”) is off and a disc is being played back.

❽ TIME key

Selects the time display type: ELAPSED, REMAIN or A-B loop duration (in A-B loop play mode).

❾ SINGLE key

Selects the play mode, either continuous play (all tracks), SINGLE (1 track) play, PROGRAM play.

❿ INDEX key

Changes to the INDEX search mode. By pressing the INDEX key, you can search by index using the SKIP keys.

When the index search mode is active, the INDEX indicator lights in the display.

⓫ SKIP keys

Use these to perform track searches (or index searches when the INDEX mode is active).

If the SKIP keys are pressed and held for more than half a second, the index number will increment or decrement appropriately. The player will go to the selected index number when the key is released.

The >>| key advances playback to the start of the next track. The |<< key sets playback to the start of the current track, or if pushed again to the start of the previous track.

If you press the keys many times, the deck will locate to the start of the track which depends on the number of times the keys were pressed.

NOTE

If you do track or index searching when the disc is being played, playback will restart after location to the track or index.

If the track or index search is performed in pause mode, the unit will enter pause mode after location to the track or index.

⓬ SEARCH keys

Use these keys to locate to the desired position.

If you press these keys when the disc is being played back, playback will restart when the desired position is reached.

If you search in pause mode, the unit will enter pause mode when the desired point is reached

2 • Front and rear panels—Remote control unit (front panel)

13 CUE key

If a cue point has been stored, the unit will play when the **CUE** key is pressed, and enter pause mode when this key is released.

14 PLAY/PAUSE key

Changes between playback and pause mode.

The key lights steadily in playback mode, and flashes in pause mode.

If the **ENTER** key 21 is pressed and held down, and the **PLAY** key is pressed at the same time, a “cross play” function is enabled where the deck whose **PLAY** key is *not* pressed will stop playback, and the deck whose **PLAY** key has been pressed will start playback.

15 JOG dial

Use this to advance or retard the playback position at a maximum resolution of 1 frame. The resolution can be set using the procedure described in 3.3.3, “Cueing using the JOG dial”.

This dial is also used for setting parameter values, etc. as explained elsewhere in this manual (3, “Basic operations” and 4, “Advanced Operations”).

16 Number keys and CLEAR key

Use these number keys for direct entry of numerical values such as direct track search, time search, preset function recall, memory storage, etc.

Use the **CLEAR** key to reset numeric values.

When the **CLEAR** key is pressed and held down and the **0** key is pressed, the number keys take on special functions, as explained in 4.6, “Number key modes”.

17 BANK key

Use to select between the five memory banks.

18 PRESET key

Allows the recall of preset functions (see 4, “Advanced Operations”).

19 MEMORY key

Memorizes the current settings.

20 RECALL key

Recalls the memories.

21 ENTER key

Confirms memory numbers, recall of memories and preset function settings.

22 BPM counter

Shows the tempo (in bpm—beats per minute—from 81 to 161) of the current track, or of the tapped tempo input with the **TAP** key 23 (see 4.5, “BPM”).

23 TAP key

Set the tempo in bpm manually by tapping the **TAP** key.

When you press this **TAP** key, the **BPM** counter 22 mode changes to the TAP mode and the **TAP** LED (to the left of the BPM counter) lights.

You can then adjust the tempo later using the dial 15.

Pressing and holding this key for more than 2 seconds resets the value.

Pressing and holding this key and the **BPM** key together allows the value to be adjusted using the dial.

24 BPM key

Selects either the automatic or tap BPM counter mode.

Clear the tempo by pressing and holding down this key for more than 2 seconds.

25 TEMPO SYNC key

Turns the tempo sync function on and off. When this function is on, the key lights up. The tempo sync function allows the playback tempo of the two decks to be synchronized (see 4.7, “Tempo Sync”).

Pressing this key will adjust the tempo of the deck to the tempo of the material being played on the other deck.

While the deck is “locking up”, the **TEMPO SYNC** key flashes, and when the sync is locked, the light lights steadily.

26 BEAT SYNC key

Turns the beat sync function on and off. The beat sync function synchronizes the playback of the decks, so that the beats in the material are synchronized with the beats in the material played back by the other deck (see 4.8, “Beat Sync”).

While the deck is “locking up”, the **BEAT SYNC** key flashes, and when the sync is locked, the light lights steadily.

27 LOOP key

Switches looping on and off. When looping is enabled, the key lights and the display indicator also lights.

2 • Front and rear panels—Remote control unit (rear)

Ⓜ A and B keys

Use the **A** and **B** keys to set, edit and recall the start and end points of the loop, respectively.

When you have set a loop (start and end points have been set), the **A** and **B** keys will light.

Ⓝ SAMPLE key

This key lights when sample playback takes place and flashes when sample recording takes place.

Press and hold this key and press the **IN** key to enter reverse sample playback mode, and press and hold this key and press the **OUT** key to enter loop sample playback mode.

Ⓞ IN/OUT keys

Use these keys to set and clear the start and end points of the sampled sound and edit the end point.

When you have set these points, these keys will light.

Start and stop sample playback using these keys.

Ⓟ SCRATCH key

Turns the scratch play mode on and off. When this scratch mode is active, the indicator lights (see 4.9, “Scratch”).

When the indicator is lit, the playback can be “scratched” using the dial.

Ⓠ BRAKE key

Turns the brake mode on and off (see 4.14, “Brake function”). When the brake mode is active, the indicator lights.

Ⓡ + and – keys

Changes the key.

These keys have no effect in Original Key mode.

Ⓢ KEY ORIGINAL/RESET key

Use to choose between the Original Key mode and and the Pitch Control mode (where the tempo or the key may be changed independently of each other).

Ⓣ TEMPO 8%/16%/32% key

Selects the maximum amount by which you can change the tempo and key (“width”).

Repeated presses of this key cycle between 8% → 16% → 32% → 0.0% → 8%.

The width is briefly shown in the display for a few seconds each time it is changed.

Ⓤ TEMPO slider

Changes the tempo when playing back a disc.

The center position is the normal tempo.

Push the slider up to the – position to decrease the tempo to the minimum set by the **TEMPO** key Ⓣ, and push it down to the + position to increase the tempo to the maximum value allowed.

2.4 Remote control unit (rear)

Ⓡ REMOTE connectors

Connect these to the **REMOTE** connectors on the rear of the main unit Ⓟ.

2.5 Display

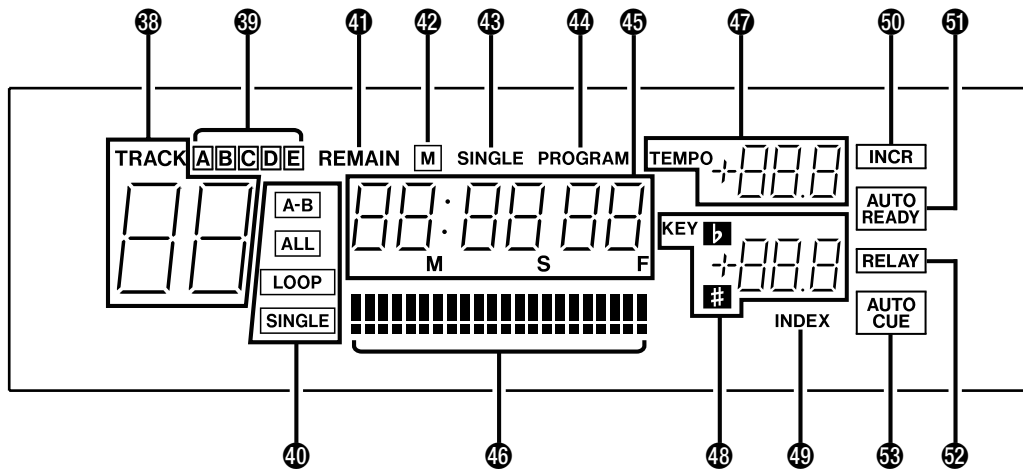

Each unit is fitted with a display, providing the following information:

38 TRACK indicator

Shows the current track.

39 Bank indicators

Show the current memory bank.

40 Loop mode indicator

Displays current loop mode (A-B, ALL, SINGLE) and loop mode on/off.

41 REMAIN indicator

Lights when the “remain” display mode is selected.

42 M (memory) indicator

Used to show memory settings.

43 SINGLE indicator

Lights when the single track playback mode is selected.

44 PROGRAM indicator

Lights when programmed playback is selected.

45 Time display

This part of the display is used to show time values or messages.

46 Time address bar

This part of the display gives a “ bargraph ” indication of the current playback position relative to the current track.

The indicator segments light from left to right when elapsed time mode is selected.

When remaining time mode is selected, indicators go out from left to right.

If an EOM (End of Message) time has been set, the bottom bar and the remaining segments will blink when the EOM time is reached.

47 TEMPO indicator

Displays the current tempo setting (playback speed).

48 KEY indicator

Displays the current key setting (the total of the key setting and the value set by the slider).

49 INDEX indicator

Lights when the index search mode is enabled (see 10).

50 INCR indicator

Lights when the Incremental Play is enabled (see 4.18, “Incremental Play”).

51 AUTO READY Indicator

Lights when the Auto Ready mode is enabled (see 4.16, “Auto Ready”).

52 RELAY Indicator

Indicates when the Relay Play mode is enabled (see 4.19, “Relay Play”). This mode is automatically enabled for both decks when it is enabled on one deck.

53 AUTO CUE Indicator

Lights when the Auto Cue mode is enabled (see 3.3.2, “Auto Cue”).

3 - Basic operations

3.1 Playback operations

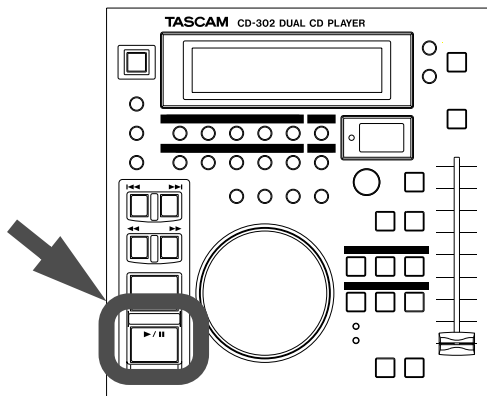

3.1.1 Playback

Load a disc in the player, and press the **PLAY/PAUSE** key.

The **PLAY/PAUSE** key lights in playback mode.

3.1.2 Pause

If you press the **PLAY/PAUSE** key during playback, the unit enters pause mode, and the **PLAY/PAUSE** key starts blinking.

3.1.3 Stop

The CD-302 has no **STOP** key. If you have turned on the Direct mode (preset function 20), you can press the **OPEN** key (on the main unit or on the remote control unit) and eject the disc even during playback.

3.2 Play modes

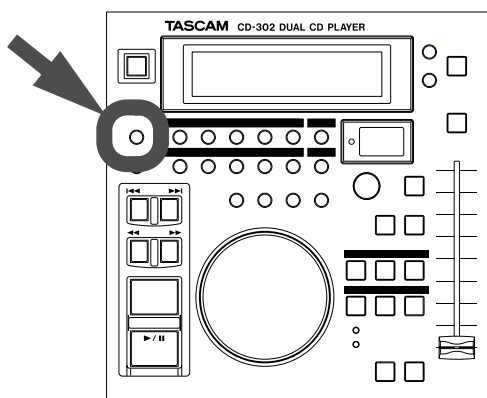

Press the **SINGLE** key, to select between the following play modes:

- all tracks playback
- single track playback
- programmed playback (up to 30 tracks can be entered)

3.2.1 Cross-play

The term “cross-playing” refers to the stopping of one deck and automatic starting of the other deck.

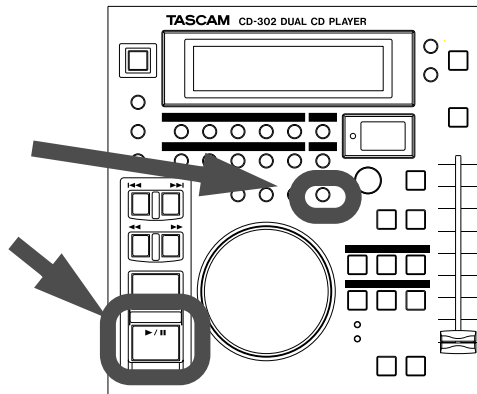

To start cross-playing:

- 1 With one deck playing, and the other stopped, press and hold down the **ENTER** key of the deck that is stopped.
- 2 Press the **PLAY** key of the stopped deck.

The deck currently playing back will stop, and the deck whose keys have been pressed will start playback.

3.3 Cueing

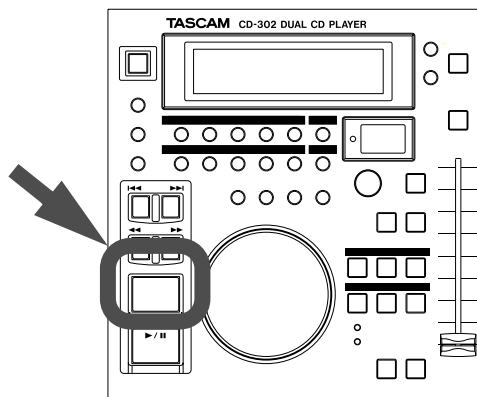

3.3.1 CUE

If a cue point has been stored, press the **CUE** key to locate to the cue point, and pause there.

To test playback from the cue point, press and hold down the **CUE** key. When the **CUE** key is released, the playback position will return to the cue point and re-enter pause mode.

There are two ways to set the cue point. Choose the way to set the cue point following the procedure below:

- 1 Press the **PRESET** key.

- 2 Select **02 CUE_P** (CUE_P) using the dial or numeric keys.
- 3 Press the **ENTER** key.
- 4 Select the cue point mode.
- 5 Press the **ENTER** key.

If you select the **PLAY** key mode (**PLY** is chosen as the cue mode value), the last playback point is captured and used as the as the cue point.

If you select the **CUE** key mode (**CUE** is chosen as the cue mode value), the operation is a little different. When the unit is paused, and searching is done using the **JOG** dial or the **SEARCH** keys, the **CUE** key will flash. Pressing the **CUE** key will store the current position as the cue point.

NOTE

You can also set the cue point using the memory function. (see 4.10, "Memories")

The cue point cannot be updated during A-B LOOP play.

3.3.2 Auto Cue

The auto cue function allows searching the track and auto-locating to the point where the audio level first goes above a set threshold level. When this point is reached, the unit enters pause mode.

Select the threshold level can be selected from:

OFF, -72, -66, -60, -54, and -35 dB.

When the auto cue function is on, the AUTO CUE indicator in the display lights.

- 1 Press the **PRESET** key.
- 2 Select **15 A_CUE** (A_CUE) using the dial or numeric keys.
- 3 Press the **ENTER** key.
- 4 Select the threshold value to be used for the auto cue function.
- 5 Press the **ENTER** key.

3.3.3 Cueing using the JOG dial

You can directly cue to any point using the **JOG** dial by frame accuracy, while the unit is in pause mode.

You can select the resolution of the dial so that one rotation of the dial is equivalent to either 9, 18, or 36 frames.

- 1 Press the **PRESET** key.

- 2 Select **03 JOG** (JOG) using the dial or numeric keys.
- 3 Press the **ENTER** key.
- 4 Select the value (frames per rotation).
- 5 Press the **ENTER** key.

3.3.4 Cueing using the SEARCH keys

You can also cue to frame accuracy, using the **SEARCH** keys to locate the playback point while the unit is in pause mode.

3.3.5 Cueing using the numeric keys

You can also cue to any point using the numeric keys.

The keys are used to enter the following values in order: track number, minutes, seconds and frames.

- 1 When you have entered the value, press the **PLAY/PAUSE** key. The unit starts playback from the input point.

If all the values are not entered, the other values are set to zero. For example, if you only enter the track number, minutes and seconds, the frames field will be set to 00, which means that the playback will start from the exact start of that second.

If you make an entry containing a mistake, the display blinks to show this.

Use the **CLEAR** key to clear and cancel entries containing mistakes.

3.4 Loop play

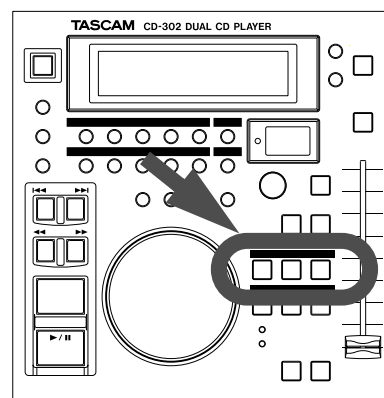

3.4.1 Selecting the loop mode

3 loop modes are available, as shown on the display:

ALL—the whole

SINGLE—a single track is repeated

A-B—between two points

3 • Basic operations—Loop play

3.4.2 A-B loop play mode

The A-B loop mode allows seamless loop play between two points (A and B). The A and B points should be in the same track.

- 1 Press the **PRESET** key.
- 2 Select \square | **LOOP** (LOOP) using the dial or numeric keys.
- 3 Press the **ENTER** key.
- 4 Select \overline{A} - \overline{B} (A-B).
- 5 Press the **ENTER** key. The A-B indicator on the display lights.

3.4.3 Setting A-B loop points

When you press the **A** or **B** key $\text{\textcircled{28}}$, you will capture the appropriate loop point.

- 1 Make sure the **A** and **B** keys are turned off (unlit). Locate to the location to be used as the start point of the loop (this can be done “on the fly” during playback).
- 2 When you press the **A** key, the current location is captured as the loop start point. The **B** key starts flashing.
- 3 Locate to the location to be used as the loop end point (or continue playback until the end point is reached).
- 4 When you press the **B** key, the current position is captured as the loop end point. If the **A** and **B** locations are different, both the **A** and **B** keys light.

If you set the loop points during playback, looped playback mode will start when both points have been set.

If you set the loop points while playback is paused, pressing the **PLAY** key will start the looped playback.

NOTE

If the Direct mode (preset function 20) is turned off, the loop points can be captured only when both the **A** and **B** keys are turned off. If the loop points have already been set, these points must be cleared before the new locations are memorized.

If the Direct mode (preset function 20) is turned on, the loop points can be set when the **LOOP** key is unlit.

3.4.4 Playback in A-B loop play mode

If you press the **LOOP** key $\text{\textcircled{27}}$ in play mode while the **A** and **B** keys are lit, loop playback mode will start

and the **LOOP** key lights. If the **A** and **B** keys are not lit, pressing the **LOOP** key will have no effect.

If the **LOOP** key is lit, and you press it again while playing back between the loop points, looped playback stops, but the unit continues to play past the end loop point.

If you press the **B** key while the unit is playing back inside the A-B loop, the point where you press the **B** key becomes the new loop end point (shortening the loop).

If you press the **PLAY/PAUSE** key while the A-B loop is being played back, playback stops.

3.4.5 Clearing loop points

When you press the **A** key and hold down the **B** key (or the other way round), the loop points are cleared.

If you play back a different track from the one containing the loop points, the loop points are also cleared.

NOTE

You can memorize the loop points for the next time you play the disc, using the memory function.

3.4.6 Editing the loop points

It is possible to edit the loop points in the following way at any time, except during loop playback.

- 1 “Double-click” (press twice in quick succession) the **A** or **B** key. The appropriate loop point is shown in the time display.
- 2 The unit enters pause mode at the **A** or **B** point (depending on the key which has been double-clicked) and the key starts flashing.
- 3 Re-set the loop point using the dial or **SEARCH** keys.
- 4 Press the **A** or **B** key (the key which was double-clicked). The new point is stored.

To cancel the loop point edit process, push any key other than the **A** or **B** key at any time before the final step.

NOTE

If Direct mode (preset function 20) is turned on, pressing either the **A** or **B** key will set the new loop point directly.

3.4.7 A-B loop duration

Show the duration of the A-B loop in the display by using the **TIME** key $\text{\textcircled{8}}$ to select this display. The

duration is shown for two seconds, and the display then returns to its previous state.

3.4.8 SINGLE loop

This plays back one track continuously, looping between the start and end of the track.

- 1 Press the **PRESET** key.
- 2 Select **LOOP** using the dial or numeric keys.
- 3 Press the **ENTER** key.
- 4 Select **S**.
- 5 Press the **ENTER** key. The **SINGLE** indicator lights in the display.

- 6 Press the **LOOP** key. The **LOOP** key lights, and the **LOOP** indicator in the display also lights.

3.4.9 ALL loop

- 1 Press the **PRESET** key.
- 2 Select **LOOP** using the dial or numeric keys.
- 3 Press the **ENTER** key.
- 4 Select **ALL**.
- 5 Press the **ENTER** key. The **ALL** indicator lights in the display.
- 6 Press the **LOOP** key. The **LOOP** key lights and the **LOOP** indicator in the display also lights.

4 - Advanced Operations

4.1 Tempo (speed) control

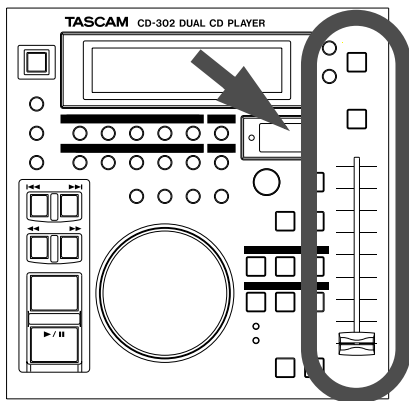

Change the tempo (playback speed) using the **TEMPO** slider **36**.

Change the maximum (full down) and minimum (full up) speeds by either 0% (disabled), $\pm 8\%$, $\pm 16\%$ or $\pm 32\%$.

- 1 Change the maximum range affected by the **TEMPO** slider **36** with repeated presses of the **TEMPO** key **35** (0%, $\pm 8\%$, $\pm 16\%$ and $\pm 32\%$).
- 2 Move the slider away from the center position in order to affect the tempo (speed) and pitch of the playback.

The further away from the center you move the slider, the more you affect the playback tempo and pitch.

If you select the 0% option, the **TEMPO** slider is disabled (moving it will have no effect). The **TEMPO** and **KEY** parts of the display show --.

4.1.1 Changing only tempo (speed)

Press the **KEY ORIGINAL** key **34** to select the “original key” mode, you can then change the playback tempo without altering the key.

The **KEY** part of the display shows -- when the original key mode is selected.

Under these circumstances, when you move the **TEMPO** slider, you will affect the tempo without altering the original key (pitch).

4.2 Key (pitch) control

You can change the key (pitch) without changing the playback tempo.

- 1 Make sure the original key mode is off (press the **KEY ORIGINAL** key **34** if necessary).

- 2 Press the + and – keys to change the key.

Display and change the key change either as a percentage of the original, or in semitone steps. Follow the steps below to select either percentage or semitone key change control.

Note that the **KEY** indicator **48** will show a total of the value shown in this way, together with any changes made using the slider (when percentage mode is selected).

4.2.1 Controlling the key change as a percentage

- 1 Press the **PRESET** key.
- 2 Select **04 KEY** (KEY) using the dial or numeric keys.
- 3 Press the **ENTER** key.
- 4 Select + using the dial.
- 5 Press the **ENTER** key.

NOTE

Press and hold the **KEY** key for more than 2 seconds to reset to 0%.

4.2.2 Controlling the key change in semitone steps

- 1 Press the **PRESET** key.
- 2 Select **04 KEY** (KEY) using the dial or numeric keys.
- 3 Press the **ENTER** key.
- 4 Select # by using the dial.
- 5 Press the **ENTER** key.

4.3 Sampling

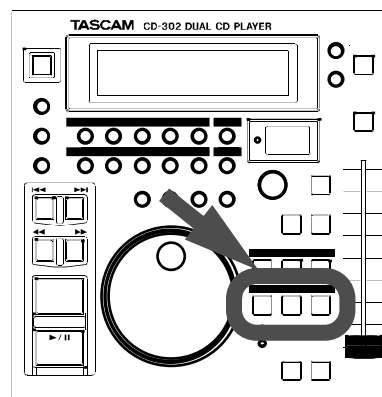

The CD-302 provides about 10 seconds of sampling time for each deck.

The points marking the start and the end of the sample must be within 10 seconds of each other, and must be in the same track.

NOTE

If the scratch function (4.9, “Scratch”) is on, you cannot use the sampling function.

4.3.1 Sampling

- 1 Make sure the IN and OUT keys  are not lit.
- 2 Erase any existing sample data (4.3.9, “Clearing the sampled data”).
- 3 Locate to the location to be used as the start point of the sample (this can be done “on the fly” during playback).
- 4 When you press the IN key, the current location is captured as the sample start point. The OUT and SAMPLE keys starts flashing as sampling starts.

The SAMPLE key will also flash if the unit is in playback mode to show that active sampling is taking place.
- 5 Locate the playback position to the location to be used as the sample end point (or continue playback until the end point is reached).
- 6 When you press the OUT key, the current position is captured as the loop point. If the start and end locations are different, both the IN and OUT keys turn on.

NOTE

If ten seconds elapse, or if the end of the track is reached without you pressing the OUT key, the end point of the sample will automatically be set at this point.

4.3.2 Using the A-B loop as a sample source

When you have set up an A-B loop (see 3.4.2, “A-B loop play mode”), you can press and hold the OUT key and press the B key (or the other way round) to set the A point of the loop as the start point of the sample, and the B point of the loop as the end point of the sample (you cannot do this when loop playback is taking place).

If the A-B loop is over 10 seconds in length the first 10 seconds will be used as the sample.

4.3.3 Editing the OUT point

You cannot edit the start point of the sample, but it is possible for you to adjust the end point to a position within 10 seconds of the start point.

- 1 With both the IN and OUT keys lit, “double-click” (i.e. press twice in quick succession) the OUT key.
- 2 The display shows the sampling time from the start point.
- 3 Use the dial to adjust the position of the end point.
- 4 Press the OUT key to store the new position of the end point.

4.3.4 Playback of sampled data

When both the IN and OUT keys are lit, press the IN key to replay the sampled data.

If you press the OUT key while the sample is being played, you will stop the sample playback.

If you press the IN key while sampled data is played back, playback restarts from the beginning of the sampling data.

4.3.5 Playback of sampled data in reverse

- 1 Press and hold down the SAMPLE key.
- 2 Press the IN key. The sample can now be played back in reverse.
- 3 Press the PLAY/PAUSE key to start reversed playback.

There is also a preset function menu which allows all samples to be played back in reverse automatically:

- 1 Press the PRESET key.
- 2 Select 05 *SAMP_P* (SAMP_P) using the dial or numeric keys.
- 3 Press the ENTER key.
- 4 Select *r* (reverse) with the dial (the *F*—forward setting sets forward play).
- 5 Press the ENTER key. The REVERSE indicator will light.

4.3.6 Setting the sampled data playback tempo

- 1 Press the PRESET key.
- 2 Select 07 *SAMP_T* (SAMP_T) using the dial or numeric keys.

4 • Advanced Operations—Bend function

- 3 Press the **ENTER** key.
- 4 Select the tempo speed using the dial.
- 5 Press the **ENTER** key.

4.3.7 Setting the sampled data playback key

- 1 Press the **PRESET** key.
- 2 Select **08 SAMP_K** (SAMP_K) using the dial or numeric keys.
- 3 Press the **ENTER** key.
- 4 Select the key pitch using the dial.
- 5 Press the **ENTER** key.

4.3.8 Looped playback of sampled data

To loop the sampled data:

- 1 Press and hold down the **SAMPLE** key.
- 2 Press the **OUT** key. This changes the mode to loop the sampled data.
- 3 Press **PLAY/PAUSE** to loop the data.

You can also set the sample loop mode as described here:

- 1 Press the **PRESET** key.
- 2 Select **05 SAMP** (SAMP) using the dial or numeric keys.
- 3 Press the **ENTER** key.
- 4 Select **01** using the dial.
- 5 Press the **ENTER** key. The **LOOP LED** will light.

4.3.9 Clearing the sampled data

If you push and hold down the **IN** key and press the **OUT** key (or the other way round) for a second or two, you will clear the sampled data.

Both the **IN** and **OUT** keys will then go out.

4.4 Bend function

The bend function allows you to change the tempo during playback by about 8% either up or down, using the dial. You need to make no settings to enable or disable this function.

Turning the dial clockwise increases the tempo, and turning it counterclockwise decreases the tempo. This action is momentary, i.e. the tempo returns to normal when the dial stops turning.

4.5 BPM

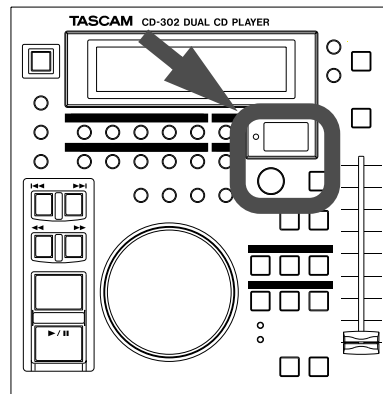

The CD-302 features a BPM (beats per minute) function for each deck. This is used in the Tempo Sync and Beat Sync functions.

4.5.1 BPM counter

The BPM counter **22** shows the tempo in beats per minute of the current material.

An automatic BPM count function and a tap mode BPM count function are available.

NOTE

It may not be possible for the CD-302 to “read” the beat automatically if the music contains complex rhythms. In this case, you should use the TAP function (described below) to determine the tempo.

4.5.2 Clearing the BPM

To clear the current BPM display, press and hold the **BPM** key **24** for two seconds or more. The BPM will then be re-read and displayed.

4.5.3 Using the tap mode with the BPM counter

Tapping the **TAP** key **23** will automatically put the unit into tap mode, as shown by the **TAP** indicator beside the BPM counter.

The tap speed, in bpm, will be shown on the BPM counter.

4.5.4 Clearing the BPM counter (tap)

Press and hold the **TAP** key for two seconds or more to clear the tapped BPM counter.

4.5.5 Editing the BPM (tap) using the dial

If you push and hold down the **TAP** key and the **BPM** key together, you can use the dial to adjust the

4 • Advanced Operations—Number key modes

tapped BPM value. Use the **ENTER** key to confirm this.

If no value is currently shown on the BPM counter, 120 is assumed as the default.

4.6 Number key modes

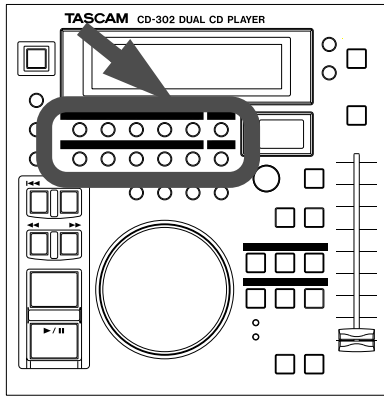

This mode allows you to set different parameters using the number keys. Usually, the number keys are used for entering track numbers and times, etc. However, they can be changed to “instant function keys”, using the following procedure.

- 1 Press and hold the **CLEAR** key **⓪**.
- 2 Press the **ENTER** key. The display will briefly show *MODE 2* (MODE 2). In this mode, the number keys change function as follows:

1 Sample key –	6 Sample key +
2 Sample tempo–	7 Sample tempo +
3 Brake time –	8 Brake time +
4 Bend –	9 Bend +
5 Voice Reduce function on/off	0

The following illustration also shows the functions of these keys:

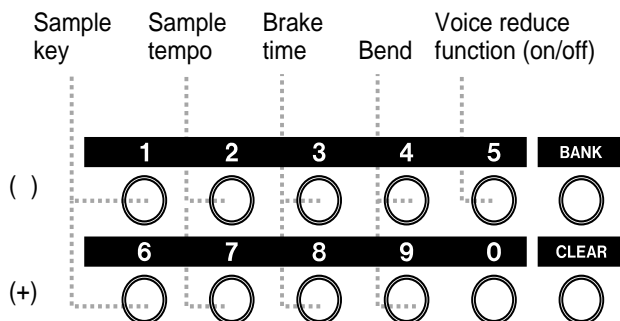

To return to normal number key mode:

- 1 Press and hold down the **CLEAR** key.

- 2 Press the **ENTER** key. The display will briefly show *MODE 1* (MODE 1); the default number key setting.

4.7 Tempo Sync

This function allows you to match tempos between the two decks of the CD-302, using the BPM facility.

In this, and the beat sync function described below, either deck can be the “master” deck (the deck from which the tempo is taken) or the “slave” deck (whose tempo is matched to that of the master).

- 1 Start playback on the master unit. The BPM counter shows the current tempo (either from the disc or from the tap function (see 4.5.3, “Using the tap mode with the BPM counter”).
- 2 Start playback on the slave unit, and press the **TEMPO SYNC** key **⓪** on the slave unit.

The **TEMPO SYNC** key will flash until the tempos are matched. After the tempos have been matched, the **TEMPO SYNC** key will light steadily.

- 3 Re-cue the slave unit so that you can start the playback at the required point.

4.7.1 Cancellation of tempo sync

The tempo sync mode will be cancelled under the following conditions:

- If the **TEMPO SYNC** key or the **BEAT SYNC** key is pressed on the master deck.
- If the **TEMPO SYNC** key is pressed on the slave deck.
- The **TEMPO** slider is moved on the slave deck.
- If the difference in tempos between the two decks (slave and master) is set to more than 32%, the **TEMPO SYNC** key will flash and then go out (tempo sync is lost).

4.8 Beat Sync

This function allows beat-level synchronization between the two decks which have already been “tempo synced” as described above (4.7, “Tempo Sync”).

The beat sync will then adjust the slave unit, so that the beats of the music played back on the two decks are synchronized (rather than simply being played

4 • Advanced Operations—Scratch

back at the same rate, as is the case with tempo sync).

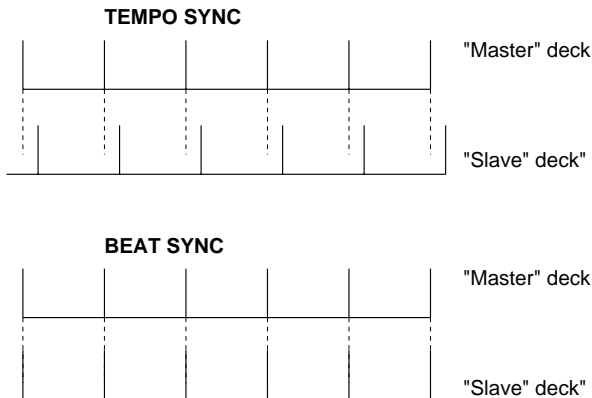

- 1 Synchronize the two decks using tempo sync, as described above. The **TEMPO SYNC** key on the slave deck should be lit.
- 2 With both decks playing, press the **BEAT SYNC** key **26** on the slave unit before you start the cross-fade between decks.

The **BEAT SYNC** key will flash until the decks are “beat synced”. After the beat sync has locked, the **BEAT SYNC** key will light steadily.

4.8.1 Cancellation of beat sync

Beat sync mode is cancelled under the following conditions:

- If the **TEMPO SYNC** key or the **BEAT SYNC** key is pressed on the master deck.
- If the **TEMPO SYNC** key or the **BEAT SYNC** key is pressed on the slave deck.
- The **TEMPO** slider is moved on the slave deck.
- The dial is used to set the BPM value on the master deck.

If beat sync is lost, it is necessary to set up the beat sync again using the **BEAT SYNC** key.

4.9 Scratch

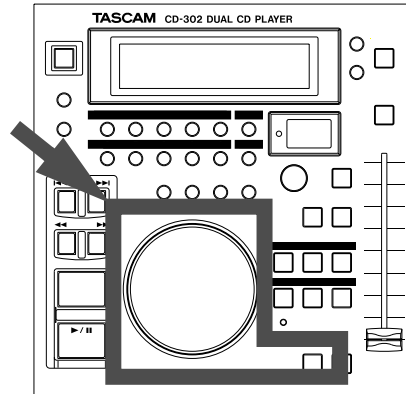

The scratch function allows you to do scratch playback, like an analog record turntable.

NOTE

Note that in the A-B loop mode (3.4.2, “A-B loop play mode”) and the single loop mode, the scratch function cannot be used.

Press the **SCRATCH** key **31** to enable the scratch mode (the key will light).

Use the dial for scratch playback, whether the deck is paused or playing back.

The “scratch area” is for five seconds “behind” the current position. The “forward” direction does not have this limitation.

To make seamless transition from scratch play to normal playback, press the **SCRATCH** key to turn off the scratch mode, while completing the scratch.

4.10 Memories

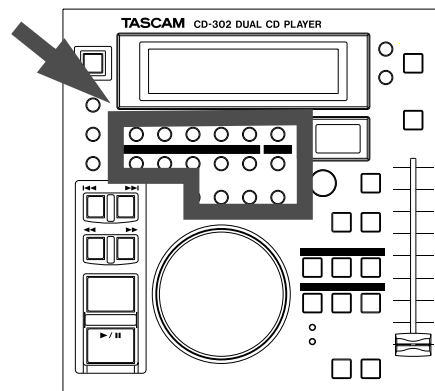

The CD-302’s memory function allows the storage of up to 1000 memories. There are 5 banks (A to E) with each bank having 200 memories.

The space for these memories is shared between the two decks, so if one player has used 1,000 memories,

there is no space remaining for the other player to use for memories.

You might use each bank for a different operator of the CD-302, for example.

The following data is stored in each memory:

- Disc ID (automatically read from disk)
- Cue point (3.3, “Cueing”)
- Loop points (A, B) (3.4, “Loop play”)
- Loop mode (A-B, SINGLE, ALL) (3.4, “Loop play”)
- Play mode (SINGLE, ALL, PROGRAM) (3.2, “Play modes”)
- Sampler points (IN, OUT) (4.3, “Sampling”)
- Sampler play mode (FWD, REVERSE) 4.3.5, “Playback of sampled data in reverse”)
- Sampler loop on/off (4.3.8, “Looped playback of sampled data”)
- Tempo (4.1, “Tempo (speed) control”)
- Tempo width (4.1, “Tempo (speed) control”)
- Key (4.2, “Key (pitch) control”)
- Tempo/Key link (4.2, “Key (pitch) control”)
- Key change amount (4.2, “Key (pitch) control”)
- Voice Reduce setting (4.11, “Voice Reduce function”)
- BPM (4.5, “BPM”)
- TAP (4.5.3, “Using the tap mode with the BPM counter”)
- Brake (ON, OFF) (4.14, “Brake function”)
- Brake time (4.14, “Brake function”)
- Time (ELAPSED, REMAIN) (3.1, “Playback operations”)
- Output level (4.13, “Output level”)

You can select whether sampling points are recalled or not using preset function 09.

When you load a disc, where a track has had a memory stored in the current bank, the display shows a flashing M for three seconds. The memory can then be recalled.

4.10.1 Storing a memory

- 1 Press the **BANK** key **17** to select the memory bank.
- 2 Press the **MEMORY** key **19**.
- 3 The display shows $\bar{n}E\bar{n}\bar{0}$ (MEMO) together with the number of the lowest empty memory available in that bank. A flashing M also appears in the display.

- 4 Change the memory number using the numeric keys or the dial.

- 5 Press **ENTER** key to complete the set up.

The display will then show a non-flashing M.

4.10.2 Recalling a memory

- 1 Press the **BANK** key **17** to select the memory bank.
- 2 Press the **RECALL** key **20**.
- 3 Select the number of the memory to be recalled using the dial or the numeric keys.
- 4 If the memory has data stored in it, the memory number will light and an M shows in the display.

If the memory has no data stored in it, the memory number flashes and M is not visible in the display.
- 5 If the memory has data stored in it, press the **ENTER** key. The memory is recalled, and the disc is located to the stored cue point.

4.10.3 Recalling a memory from a track number

- 1 Press the **BANK** key **17** to select the memory bank.
- 2 Press the **RECALL** key.
- 3 If memory data exists in the currently-selected bank for the current track, the M sign will light steadily.
- 4 Press the **ENTER** key to recall the memory. The track will pause at the recalled cue point.

4.10.4 Overwriting a memory

- 1 Press the **BANK** key **17** to select the memory bank.
- 2 Press the **MEMORY** key **19**.
- 3 The word *-SURE-* (SURE) will appear in the display.
- 4 Press the **ENTER** key to confirm the overwrite procedure. The memory related to the currently-selected track is overwritten.

4.10.5 Memory recall (sample points)

To avoid accidentally overwriting sample points, you can select whether to recall sampling points or not when a memory is recalled.

4 • Advanced Operations—Voice Reduce function

- 1 Press the **PRESET** key.
- 2 Select **09 SAMP_R** (SAMP_R) using the dial or numeric keys.
- 3 Press the **ENTER** key.
- 4 Select **0n** or **0FF** using the dial.
- 5 Press the **ENTER** key.

However, even if the sampling point recall is set to off, memorized sample data can still be loaded later:

- 1 **Recall the memory** (see 4.10.2, “Recalling a memory”). If sample points have been stored in the memory, the **IN** and **OUT** keys will flash three times.
- 2 **Pause playback.**
- 3 **Press and hold the OUT key for more than two seconds.**

The sample data are loaded, and the **IN** and **OUT** keys will light.

4.10.6 Clearing memories

It is possible to clear all memories together, or clear them individually.

To clear individual memories:

- 1 **Recall the memory.**
- 2 **M** will show on the display.
- 3 **Press and hold the MEMORY key** **19** for two seconds or longer.
- 4 **The M in the display will go out.**

To clear all memories.

- 1 Press the **PRESET** key.
- 2 Select **24 ALL_CL** (ALL_CL) using the dial or numeric keys.
- 3 Press the **ENTER** key. The display will show **-SURE-** (-SURE-).
- 4 Press the **ENTER** key to confirm the deletion of all memories.

NOTE

If you are clearing all memories and then turning off the power, wait a few seconds between pressing the **ENTER** key and turning off the power.

4.11 Voice Reduce function

This function lowers the volume of the vocal part of the material being played back when enabled. Note that this may work better on some recordings than others.

- 1 Press the **PRESET** key.
- 2 Select **10 VOICE_R** (VOICE_R) using the dial or numeric keys.
- 3 Press the **ENTER** key.
- 4 Select **0n** or **0FF** using the dial.
- 5 Press the **ENTER** key to confirm this setting.

4.12 Programmed playback

Add up to 30 tracks to a program for programmed playback in a series of program steps.

Even when the power is turned off, if you have set a programmed playback order set and enabled timer play, programmed playback will start when the unit is turned on, as the program is stored in memory.

4.12.1 Setting the program steps

This adds tracks as program steps in a new program.

- 1 Press the **PRESET** key.
- 2 Select **11 PR06** (PROG) using the dial or numeric keys.
- 3 Press the **ENTER** key. The program step number and the track number are shown on the display.
- 4 Use the **SKIP keys** **12** to select the track to be played as the currently-shown program step.
- 5 Press the **ENTER** key to confirm the entry.
- 6 Repeat 4 and 5 above for as many steps as will be entered into the program.
- 7 To finish the program entry sequence, press the **PRESET** or **ENTER** key (or any key except the **SKIP** keys).

4.12.2 Adding tracks to the middle of a program

When you have created a program, you can insert tracks as new program steps part of the way through the program.

- 1 Press the **PRESET** key.

4 • Advanced Operations—Output level

- 2 Select *11 Pr 05* (PROG) using the dial or numeric keys.
- 3 Press the ENTER key. The track number, followed by the program step number (e.g. *Pr 0 05* (PRO 05)), is shown on the display.
- 4 Use the dial to select the position in the program where the new program step is to be inserted.
- 5 Use the SKIP keys **Ⓜ** to select the track to be played as the program step which will be inserted.
- 6 Press the ENTER key. All program steps following the step which has just been entered will have 1 added to their step numbers.
- 7 Repeat 5 and 6 above for as many steps as will be inserted into the program.
- 8 To finish the program entry sequence, press the PRESET or ENTER key (or any key except the SKIP keys).

4.12.3 Deleting program steps

This function allows you to delete individual program steps from the program.

- 1 Press the PRESET key.
- 2 Select *11 Pr 05* (PROG) using the dial or numeric keys.
- 3 Press the ENTER key. The program step number and the track number are shown on the display.
- 4 Use the dial to select the track to be deleted.
- 5 Use the SKIP keys **Ⓜ** to select *E* (E) (“before” the first track).
- 6 Press the ENTER key to delete the track. Program steps following the deleted program step will 1 subtracted from their step numbers.
- 7 Repeat steps 5 and 6 for as many tracks as are to be deleted.
- 8 To finish the program step deletion sequence, press the PRESET or ENTER key (or any key except the SKIP keys).

4.12.4 Deleting a whole program

This procedure deletes the whole of the program (all the program steps).

- 1 Press the PRESET key.

- 2 Select *11 Pr 05* (PROG) using the dial or numeric keys.
- 3 Press the ENTER key. The program step number and the track number are shown on the display.
- 4 Use the dial to display *Pr 0 E* (PRO E).
- 5 Press the ENTER key. The display will show *-SURE-* (-SURE-).
- 6 Press the ENTER key one more time to delete the whole program.

NOTE

Opening the disc tray will also clear the whole of the program.

4.13 Output level

You can adjust the output level digitally in steps from +6 to -6, or set to *nor* (NOR=normal).

The *nor* setting is equivalent to the +6 setting (maximum output level is 2 V_{p-p}). The maximum output level of the 0 setting is 1 V_{p-p}. The amplification chain must be used to make up volume if required.

- 1 Press the PRESET key.
- 2 Select *12 OUTPUT* (OUTPUT) using the dial or numeric keys.
- 3 Press the ENTER key.
- 4 Use the dial to select the value by which the output level will be cut or boosted.
- 5 Press the ENTER key to confirm the setting.

4.14 Brake function

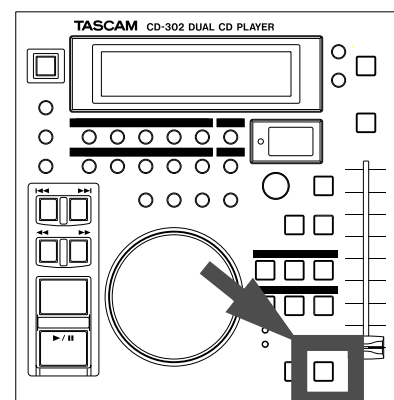

Brake function allows the braking of the audio just like turning off an analog record turntable.

4 • Advanced Operations—Setting the EOM time

When the **BRAKE** key is pressed, it lights, and the brake mode is active.

When you are playing a disc with brake mode active, and you press the **PLAY/PAUSE** key, the deck will stop playback slowly, like a record turntable.

Select the braking time from 0.2 to 5.0 seconds, in 0.1 second steps.

- 1 Press the **PRESET** key.
- 2 Select *13 brAKE* (BRAKE) using the dial or numeric keys.
- 3 Press the **ENTER** key.
- 4 Use the dial to select a value.
- 5 Press the **ENTER** key.

4.15 Setting the EOM time

The EOM (End of Message) time is a fixed time before the end of the current track. When playing back, and this EOM time is reached, the time address bar **46** in the display will flash. This provides you with a clear visual indication that the end of the track is coming up.

- 1 Press the **PRESET** key.
- 2 Select *14 EOM* (EOM) using the dial or numeric keys.
- 3 Press the **ENTER** key.
- 4 Select a value. The possible values available for the EOM time are: *OFF*, *10*, *15*, *20*, *30*, *50* and *90* seconds. If *OFF* is selected, the time address bar will not flash near the end of the track.
- 5 Press the **ENTER** key to confirm the setting.

4.16 Auto Ready

When you set the Auto Ready function, and a track is played back, the deck will automatically enter pause mode at the start of the next track on the disc. In single play mode (3.2, “Play modes”) this setting has no effect.

This is in contrast to single play mode (3.2, “Play modes”), where the unit relocates to the start of the current track.

- 1 Press the **PRESET** key.
- 2 Select *16 A_rEdY* (A_REDY) using the dial or numeric keys.
- 3 Press the **ENTER** key.
- 4 Select *ON* or *OFF* to turn the function on or off.
- 5 Press the **ENTER** key.

4.17 Timer Play

When the power is turned on, playback will automatically start on the deck on which this Timer Play function is enabled.

If this function has been enabled for both decks, only the left deck will start to play when power is turned on.

- 1 Press the **PRESET** key.
- 2 Select *17 T_PLAY* (T_PLAY) using the dial or numeric keys.
- 3 Press the **ENTER** key.
- 4 Select *ON* or *OFF* to turn the function on or off.
- 5 Press the **ENTER** key.

4.18 Incremental Play

When the Incremental Play function is enabled, it allows automatic cueing of the playback position to the next track when the unit is in playback mode, and a fader stop command is received (see 4.23, “Fader and Event Start/Stop”).

- 1 Press the **PRESET** key.
- 2 Select *18 I_PLAY* (I_PLAY) using the dial or numeric keys.
- 3 Press the **ENTER** key (INCR is shown in the display).
- 4 Select *ON* or *OFF* to turn the function on or off.
- 5 Press the **ENTER** key.

4.19 Relay Play

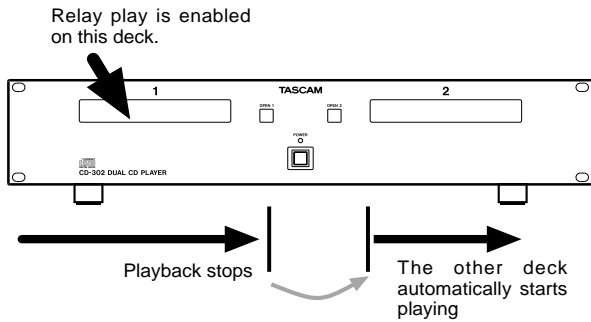

When you set the Relay Play function you enable the automatic start of playback by a deck when the other deck stops playback. Setting relay play on one deck enables relay play on both decks.

- 1 Press the **PRESET** key.
- 2 Select *19 r_PLAY* (R_PLAY) using the dial or numeric keys.
- 3 Press the **ENTER** key.
- 4 Select *On* or *OFF* to turn the function on or off.
- 5 Press the **ENTER** key.

4.20 Direct mode

When the Direct mode is enabled:

- the **OPEN** keys (**2** and **7**) can open the disc trays while a disc is being played back in the appropriate tray.
- When a disc tray is closed, the deck automatically starts playback.
- When the **LOOP** key is unlit, the A or B points can be directly overwritten.

- 1 Press the **PRESET** key.
- 2 Select *20 dIrEct* (DIRECT) using the dial or numeric keys.
- 3 Press the **ENTER** key.
- 4 Select *On* or *OFF* to turn the function on or off.
- 5 Press the **ENTER** key.

4.21 Disc Tray Auto Close

When you enable this function, any disc tray that is open will close automatically after one minute.

- 1 Press the **PRESET** key.
- 2 Select *21 cLOSE* (CLOSE) using the dial or numeric keys.
- 3 Press the **ENTER** key.
- 4 Select *On* or *OFF* to turn the function on or off.
- 5 Press the **ENTER** key.

4.22 Sleep

When you enable this function, if there is no activity on the unit for 30 minutes or more, the deck motors will turn off and the displays will also turn off (they will turn on automatically when a key is next pressed).

- 1 Press the **PRESET** key.
- 2 Select *22 SLEEP* (SLEEP) using the dial or numeric keys.
- 3 Press the **ENTER** key.
- 4 Select *On* or *OFF* to turn the function on or off.
- 5 Press the **ENTER** key.

4 • Advanced Operations—Fader and Event Start/Stop

4.23 Fader and Event Start/Stop

You can control the CD-302's decks individually by using fader start and event start through the appropriate jacks ⑥ on the rear panel of the main unit.

Fader start can be used to stop and start the units.

Event start can be used to start the units only.

The TRS (tip-ring-sleeve) jacks should be wired as shown below:

The fader switch should be wired to the tip and sleeve of the TRS plug.

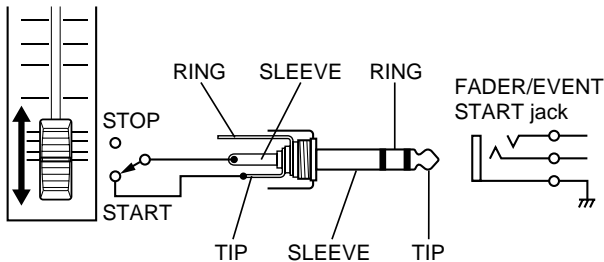

The event trigger switch should be wired to the ring and sleeve of the TRS plug.

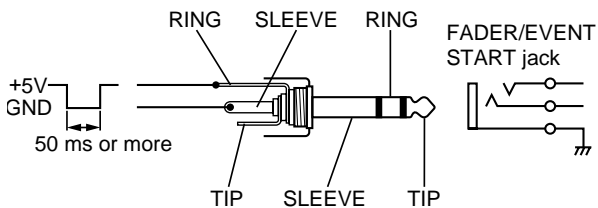

An event trigger should pull down to ground from +5 V for 50 ms or more.

4.24 Factory Preset

To restore all settings to their factory defaults (as described in the table in 1.7, "Preset functions"):

- 1 Press the **PRESET** key.
- 2 Select *23 F_PrE* (F_PRE) using the dial or numeric keys.
- 3 Press the **ENTER** key.
- 4 The display shows *-SUR E-*.
- 5 Press the **ENTER** key to restore all settings to their default values.

5 - Specifications and reference

5.1 Specifications

Disc types	8 cm/12 cm CD
Number of channels	2 channel
Resolution	16-bit
Sampling frequency	44.1 kHz
DA conversion	16-bit, 8x oversampling
Output impedance	< 1 kΩ
Maximum output level	+6 dBV

Voltage requirements	USA/Canada 120 VAC, 60 Hz U.K./Europe 230 VAC, 50 Hz Australia 240 VAC, 50 Hz
----------------------	---

Power consumption	32 W
Applicable electromagnetic environment	E4

Peak inrush current	0.8 A
---------------------	-------

Dimensions w x h x d (main unit — 2U)	482 x 88 x 261 (mm) 19 x 3.5 x 10.3 (in)
(remote control units – 5U)	482 x 220 x 87 (mm) 19 x 8.7 x 3.4 (in)

Weight (main unit)	5.9 kg (13 lbs)
(remote control units)	3.9 kg (6.6 lbs)

The following values are applicable when the key and tempo values are set to 0:

Frequency response	20 Hz — 20 kHz ± 1.0 dB
Dynamic range	> 98 dB
S/N ratio	> 98 dB (IHF-A)
Total harmonic distortion	< 0.006%

5.1.1 Dimensions

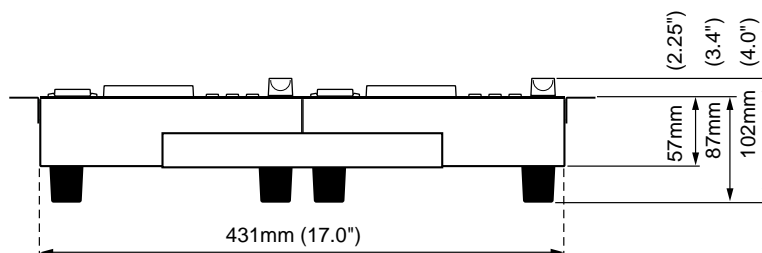
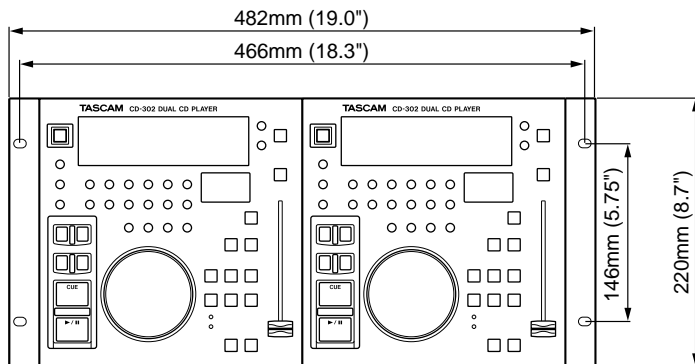
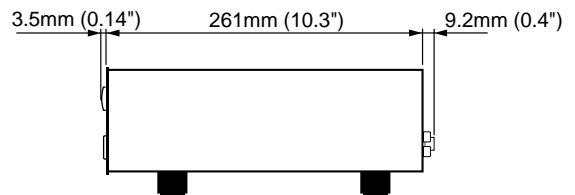
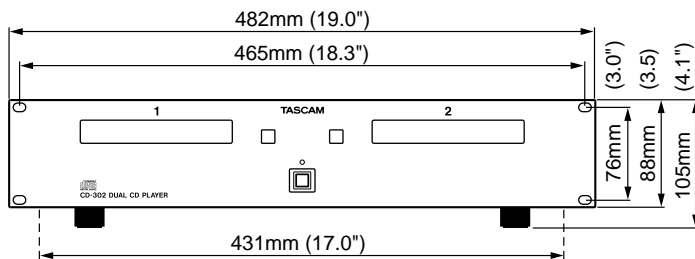

5.2 Error messages, etc.

<i>no disc</i>	NO DISC	No disc is inserted in the tray—insert a disc or remove and replace the disc already loaded
<i>Err 01</i>	ERROR 1	No disc—the unit cannot find focus on a disc (after retrying several times)
<i>Err 02</i>	ERROR 2	Unused
<i>Err 03</i>	ERROR 3	TOC Read error—the disc's Table of Contents cannot be read within 20 seconds—try with another disc or remove and clean the existing disc before replacing it
<i>Err 04</i>	ERROR 4	GFS error—a GFS error has occurred 3 times within five seconds—try with another disc or remove and clean the existing disc before replacing it
<i>Err 05</i>	ERROR 5	Focus error—after repeating the attempt eight times to focus, an error still occurs—try with another disc or remove and clean the existing disc before replacing it
<i>Err 06</i>	ERROR 6	Sub-Q error—the sub-Q code cannot be detected (twice within five seconds)—try with another disc
<i>Err 07</i>	ERROR 7	Loading error—the open or close operation cannot be completed, even after retries, or there is an internal error—make sure that there are no obstructions preventing the tray's operation
<i>Err 08</i>	ERROR 8	Sled error—an internal drive error—try turning the power off, waiting a few seconds, and turning it on again
<i>Err 09</i>	ERROR 9	Error in communication between decks—try turning the unit off, waiting a few seconds, and turning it on again

If any of the numbered error messages (1 through 9) occur, try using another disc.

If the errors continue with a number of discs, turn the unit off, wait for a few seconds, and turn it on again.

If the errors still continue, contact your TASCAM distributor for repair.

5.2.1 Spare parts

The following spare parts are readily available from your TASCAM distributor should the original such parts supplied with your CD-302 become damaged.

9260337700 Joint angle

9783243006 Screw for installing Joint angle

9109030600 Remote cable