

How to...

change to USB mode from audio mode? With the unit in standby mode, and disconnected from the computer, use the **MENU** key and the **MULTI DIAL** to display **USB MODE**. Connect the CD-RW4U to the computer.

change to audio mode from USB mode? With the unit in standby, use the **MENU** key and the **MULTI DIAL** to display **AUDIO MODE**. Then turn the CD-RW4U on with the **POWER** key.

choose whether to record from the digital or analog inputs? Use the **INPUT SELECT** on the main unit (not the remote control unit) to choose between **Analog In** and **Coaxial In**.

start recording a track automatically when the source material starts? Press the **SYNC REC** key to put the unit into sync mode. Once the input level goes over the trigger level set up in the menu, the CD-RW4U starts recording.

find out how much time is left on a recordable disc? When a recordable disc is in the drive, press the **DISPLAY** key on the remote control unit until the display shows **TOTAL REMAIN** and the amount of time available for recording.

prevent the recorder making a new track every time there's a quiet passage in the music? Use the menu system to set the auto track function off, or reset the trigger level so that quieter passages don't start a new track.

adjust the input level when recording? For recording from analog sources, use the front panel **INPUT** level to adjust the volume. For digital recordings, use the **VOLUME** menu to cut or boost the digital signal. Never let the meters go to the **OVER** mark.

erase a mistake? You can only erase tracks on unfinalized CD-RW discs. Only the last tracks can be erased (you can't erase a track in the middle of a disc).

reuse a disc that's been recorded and finalized? You can only reuse CD-RW discs. If the disc has been finalized, you must unfinalize it first. Use the **ERASE** key on the remote control and select **Unfinalize** by turning the **MULTI DIAL** or using the **SKIP** keys. Then erase all the tracks by pressing the **MULTI DIAL** or **ENTER** key.

This product is designed to help you record and reproduce sound works to which you own the copyright, or where you have obtained permission from the copyright holder or the rightful licensor. Unless you own the copyright, or have obtained the appropriate permission from the copyright holder or the rightful licensor, your unauthorized recording, reproduction or distribution thereof may result in severe criminal penalties under copyright laws and international copyright treaties. If you are uncertain about your rights, contact your legal advisor. Under no circumstances will TEAC Corporation be responsible for the consequences of any illegal copying performed using the CD-RW4U.

TASCAM CD-RW4U

Quick Start Guide

Using the menus

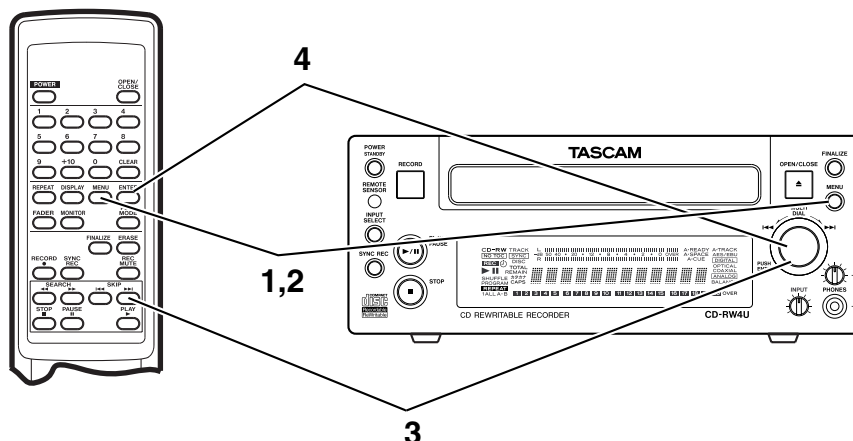

- 1 With the CD-RW4U in stop mode, press the MENU key on the main unit or the remote control.
- 2 Continue to press the MENU key until the desired menu appears on the display.
- 3 Change the menu parameter by turning the MULTI DIAL (main unit) or pressing the SKIP keys (remote control unit).
- 4 Exit the menu system by pressing the MULTI DIAL or pressing the ENTER key (remote control unit).

Menu	Meaning	Values
A_TRACK	Auto track division when recording	OFF, ON
S_LVL	Trigger level for track division	MIN L, DD, -24, -30, -36, -42, -48, -54, -60, -66, -72 (dB)
COPY ID	SCMS copy-protection	FREE, 1GEN, PROH
FADE IN	Time taken to fade in when recording	1 through 24 seconds
FADE OUT	Time taken to fade out when recording	1 through 24 seconds
PWR SAVE	Switches unit to standby mode if left unattended for five minutes	ON, OFF

Playback

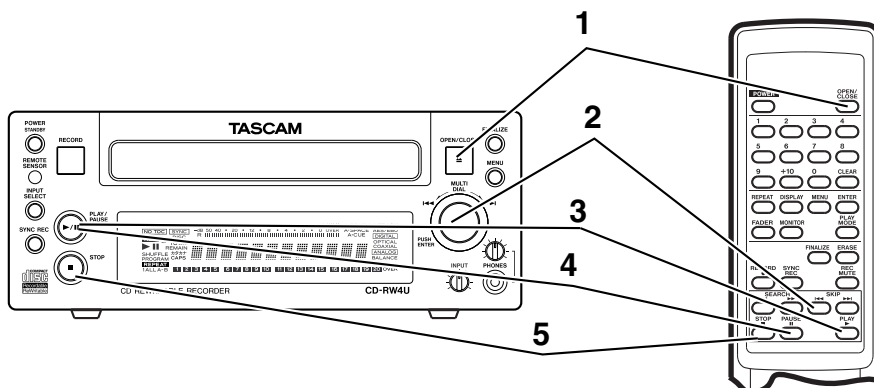

- 1 Insert the disc (use the OPEN/CLOSE key). Wait until the **TOC Reading.** message disappears from the display.
- 2 Select a track for playback by turning the **MULTI DIAL** (main unit) or using the **SKIP** keys (remote control unit).
- 3 Start playback by pressing the **PLAY/PAUSE** key (main unit) or the **PLAY** key (remote control unit).
- 4 Pause playback with the **PLAY/PAUSE** key (main unit) or the **PAUSE** key (remote control unit).
- 5 Stop playback with the **STOP** key (main or remote control unit).

Programmed playback

- 1 Press the **PLAY MODE** key (remote control unit) until the display shows **Program.**
- 2 Use the **MULTI DIAL** (main unit) or **SKIP** keys (remote control unit) to select a program step.
- 3 Press the **MULTI DIAL** or the **ENTER** key (remote control unit).
- 4 Repeat 3 and 4 as often as needed.
- 5 Start playback (**PLAY/PAUSE** or **PLAY**).

Recording

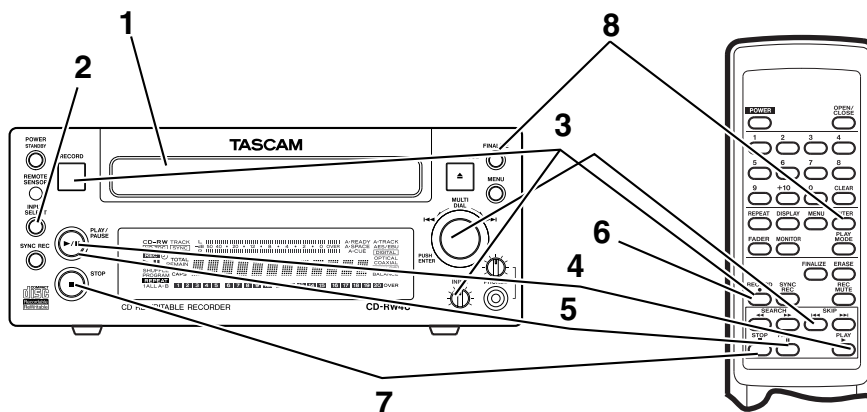

- 1 Insert a recordable disc.
- 2 Select the source (analog or digital) with the **INPUT SELECT** key.
- 3 Monitor the input by pressing **RECORD**. If you selected the analog input jacks, you can adjust the input level with the **INPUT** control knob (main unit). Use the **VOLUME** menu system to adjust digital levels if necessary. Avoid clipping.
- 4 Press the **PLAY/PAUSE** (main unit) or **PLAY** key (remote control unit) to start recording.
- 5 Press the **PLAY/PAUSE** or **PAUSE** key to pause recording. When you restart recording, a new track will be started.
- 6 Enter track divisions “on-the-fly” by pressing **RECORD** (either the main unit or remote control unit).
- 7 Finish the recording session by pressing **STOP**. Add more tracks if desired.
- 8 Finalize the disc before playing it back on an ordinary CD player. Press **FINALIZE** (main unit), followed by pressing the **MULTI DIAL** (main unit) or the **ENTER** key (remote control unit).

Safety precautions

- Although some of these precautions may seem obvious, we strongly suggest that you read and take note of them in order to avoid any possible trouble with your CD-RW4U. Full safety instructions are included in the manual.
- Read the manual and keep it in a convenient place! The manual can be your friend in times of trouble. Read the manual to find out what's there and what the CD-RW4U can do, follow the instructions in the manual, and take note of the notes and warnings.
- If the unit needs to be cleaned, disconnect it from the power supply first. Use a damp cloth for cleaning, and avoid using liquid cleaners or aerosol cleaners.
- Only use any accessories or attachments recommended by TEAC. Use of any other accessories or attachments may prove dangerous, to you and the unit. The CD-RW4U can use a variety of recordable CD media. Since this technology is moving forward rapidly, we suggest that you visit the TASCAM Web site (<http://www.tascam.com>) for up-to-date details of what media are supported. If you do not have Internet access, consult your TASCAM distributor.
- Don't use this unit in an environment where it can get wet or damp. Don't spill liquid onto it, or push anything (screwdrivers, etc.) through the slots in the case. Also make sure that the unit does not become overheated. Keep it away from radiators, stoves, or other sources of heat (including amplifiers, etc.).
- Always make sure that the unit is mounted firmly and securely where it cannot fall, causing damage to the unit or injury to people. If you are moving the unit on a cart, take care that it does not fall over.
- Never block any slots in the case—these are necessary for proper ventilation of the internal parts. You should never operate the unit when it is on a bed, rug or soft furnishings, as this can impede the airflow.
- The power supply should always correspond to the specifications marked on the label on the rear panel. If you are in any doubt, consult a qualified electrician to check your power supply. Always route the power cord where it will not be trapped or pinched, and where you will not trip over it. Do not overload sockets, power adaptors or extension cords.
- If the plug supplied with this unit is polarized (one blade of the plug is wide than the other) do not attempt to fit the plug the wrong way round into an outlet. If the plug will not fit into the outlet, consult a qualified electrician to change the outlet.
- We suggest unplugging the unit from the power supply during electrical storms, or when it will not be used for a long time.
- The CD-RW4U is a complex piece of equipment. If anything goes wrong, do not attempt to repair it yourself, but have it repaired by qualified service personnel if it ceases to function properly, is dropped or damaged, or if it becomes wet, etc. Always make sure that any replacement parts are those specified by TEAC.