

TASCAM

TEAC Professional Division

DA-302

Dual Digital Audio Tape Deck

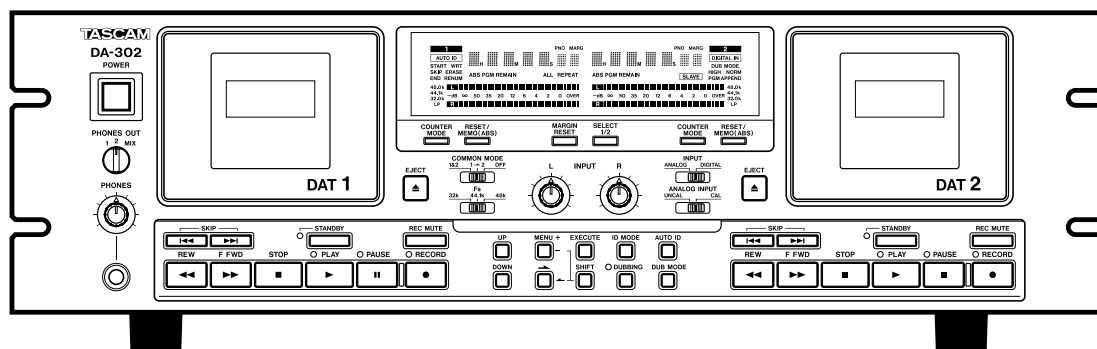

OWNER'S MANUAL

D00313200A

Important Safety Precautions



CAUTION: TO REDUCE THE RISK OF ELECTRIC SHOCK, DO NOT REMOVE COVER (OR BACK). NO USER-SERVICEABLE PARTS INSIDE. REFER SERVICING TO QUALIFIED SERVICE PERSONNEL.



The lightning flash with arrowhead symbol, within equilateral triangle, is intended to alert the user to the presence of uninsulated "dangerous voltage" within the product's enclosure that may be of sufficient magnitude to constitute a risk of electric shock to persons.



The exclamation point within an equilateral triangle is intended to alert the user to the presence of important operating and maintenance (servicing) instructions in the literature accompanying the appliance.

This appliance has a serial number located on the rear panel. Please record the model number and serial number and retain them for your records.

Model number _____
Serial number _____

WARNING: TO PREVENT FIRE OR SHOCK HAZARD, DO NOT EXPOSE THIS APPLIANCE TO RAIN OR MOISTURE.

Important (for U.K. Customers)

DO NOT cut off the mains plug from this equipment. If the plug fitted is not suitable for the power points in your home or the cable is too short to reach a power point, then obtain an appropriate safety approved extension lead or consult your dealer.

If nonetheless the mains plug is cut off, remove the fuse and dispose of the plug immediately, to avoid a possible shock hazard by inadvertent connection to the mains supply.

If this product is not provided with a mains plug, or one has to be fitted, then follow the instructions given below:

IMPORTANT: The wires in this mains lead are coloured in accordance with the following code:

GREEN-AND-YELLOW : EARTH
BLUE : NEUTRAL
BROWN : LIVE

WARNING: This apparatus must be earthed.

As the colours of the wires in the mains lead of this apparatus may not correspond with the coloured markings identifying the terminals in your plug proceed as follows:

The wire which is coloured GREEN-and-YELLOW must be connected to the terminal in the plug which is marked by the letter E or by the safety earth symbol \equiv or coloured GREEN or GREEN-and-YELLOW.

The wire which is coloured BLUE must be connected to the terminal which is marked with the letter N or coloured BLACK.

The wire which is coloured BROWN must be connected to the terminal which is marked with the letter L or coloured RED.

When replacing the fuse only a correctly rated approved type should be used and be sure to re-fit the fuse cover.

IF IN DOUBT — CONSULT A COMPETENT ELECTRICIAN.

For U.S.A.

TO THE USER

This equipment has been tested and found to comply with the limits for a Class A digital device, pursuant to Part 15 of the FCC Rules. These limits are designed to provide reasonable protection against harmful interference when the equipment is operated in a commercial environment. This equipment generates, uses, and can radiate radio frequency energy and, if not installed and used in accordance with the instruction manual, may cause harmful interference to radio communications.

Operation of this equipment in a residential area is likely to cause harmful interference in which case the user will be required to correct the interference at his own expense.

CAUTION

Changes or modifications to this equipment not expressly approved by TEAC CORPORATION for compliance could void the user's authority to operate this equipment.

For the consumers in Europe

WARNING

This is a Class A product. In a domestic environment, this product may cause radio interference in which case the user may be required to take adequate measures.

Pour les utilisateurs en Europe

AVERTISSEMENT

Il s'agit d'un produit de Classe A. Dans un environnement domestique, cet appareil peut provoquer des interférences radio, dans ce cas l'utilisateur peut être amené à prendre des mesures appropriées.

Für Kunden in Europa

Warnung

Dies ist eine Einrichtung, welche die Funk-Entstörung nach Klasse A besitzt. Diese Einrichtung kann im Wohnbereich Funkstörungen verursachen ; in diesem Fall kann vom Betreiber verlangt werden, angemessene Maßnahmen durchzuführen und dafür aufzukommen.

Safety Instructions

CAUTION:

- Read all of these Instructions.
- Save these Instructions for later use.
- Follow all Warnings and Instructions marked on the audio equipment.

- 1) **Read instructions** — All the safety and operating instructions should be read before the product is operated.
- 2) **Retain instructions** — The safety and operating instructions should be retained for future reference.
- 3) **Heed Warnings** — All warnings on the product and in the operating instructions should be adhered to.
- 4) **Follow instructions** — All operating and use instructions should be followed.
- 5) **Cleaning** — Unplug this product from the wall outlet before cleaning. Do not use liquid cleaners or aerosol cleaners. Use a damp cloth for cleaning.
- 6) **Attachments** — Do not use attachments not recommended by the product manufacturer as they may cause hazards.
- 7) **Water and Moisture** — Do not use this product near water – for example, near a bath tub, wash bowl, kitchen sink, or laundry tub; in a wet basement; or near a swimming pool; and the like.
- 8) **Accessories** — Do not place this product on an unstable cart, stand, tripod, bracket, or table. The product may fall, causing serious injury to a child or adult, and serious damage to the product. Use only with a cart, stand, tripod, bracket, or table recommended by the manufacturer, or sold with the product. Any mounting of the product should follow the manufacturer's instructions, and should use a mounting accessory recommended by the manufacturer.
- 9) A product and cart combination should be moved with care. Quick stops, excessive force, and uneven surfaces may cause the product and cart combination to overturn.



- 10) **Ventilation** — Slots and openings in the cabinet are provided for ventilation and to ensure reliable operation of the product and to protect it from overheating, and these openings must not be blocked or covered. The openings should never be blocked by placing the product on a bed, sofa, rug, or other similar surface. This product should not be placed in a built-in installation such as a bookcase or rack unless proper ventilation is provided or the manufacturer's instructions have been adhered to.
- 11) **Power Sources** — This product should be operated only from the type of power source indicated on the marking label. If you are not sure of the type of power supply to your home, consult your product dealer or local power company. For products intended to operate from battery power, or other sources, refer to the operating instructions.
- 12) **Grounding or Polarization** — This product may be equipped with a polarized alternating-current line plug (a plug having one blade wider than the other). This plug will fit into the power outlet only one way. This is a safety feature. If you are unable to insert the plug fully into the outlet, try reversing the plug. If the plug should still fail to fit, contact your electrician to replace your obsolete outlet. Do not defeat the safety purpose of the polarized plug.
- 13) **Power-Cord Protection** — Power-supply cords should be routed so that they are not likely to be walked on or pinched by items placed upon or against them, paying particular attention to cords at plugs, convenience receptacles, and the point where they exit from the product.
- 14) **Outdoor Antenna Grounding** — If an outside antenna or cable system is connected to the product, be sure the antenna or cable system is grounded so as to provide some protection against voltage surges and built-up static charges. Article 810 of the National Electrical Code, ANSI/NFPA 70, provides information with regard to proper grounding of the mast and supporting structure, grounding of the lead-in wire to an antenna discharge unit, size of grounding conductors, location of antenna-discharge unit, connection to grounding electrodes, and requirements for the grounding electrode.

"Note to CATV system installer:

This reminder is provided to call the CATV system installer's attention to Section 820-40 of the NEC which provides guidelines for proper grounding and, in particular, specifies that the cable ground shall be connected to the grounding system of the building, as close to the point of cable entry as practical.

Example of Antenna Grounding as per National Electrical Code, ANSI/NFPA 70

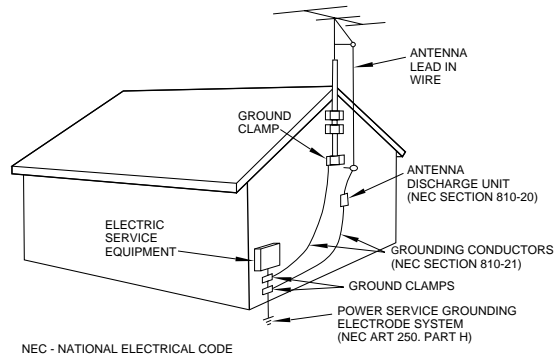

- 15) **Lightning** — For added protection for this product during a lightning storm, or when it is left unattended and unused for long periods of time, unplug it from the wall outlet and disconnect the antenna or cable system. This will prevent damage to the product due to lightning and power-line surges.
- 16) **Power Lines** — An outside antenna system should not be located in the vicinity of overhead power lines or other electric light or power circuits, or where it can fall into such power lines or circuits. When installing an outside antenna system, extreme care should be taken to keep from touching such power lines or circuits as contact with them might be fatal.
- 17) **Overloading** — Do not overload wall outlets, extension cords, or integral convenience receptacles as this can result in risk of fire or electric shock.
- 18) **Object and Liquid Entry** — Never push objects of any kind into this product through openings as they may touch dangerous voltage points or short-out parts that could result in a fire or electric shock. Never spill liquid of any kind on the product.
- 19) **Servicing** — Do not attempt to service this product yourself as opening or removing covers may expose you to dangerous voltage or other hazards. Refer all servicing to qualified service personnel.
- 20) **Damage Requiring Service** — Unplug this product from the wall outlet and refer servicing to qualified service personnel under the following conditions:
 - a) when the power-supply cord or plug is damaged.
 - b) if liquid has been spilled, or objects have fallen into the product.
 - c) if the product has been exposed to rain or water.
 - d) if the product does not operate normally by following the operating instructions. Adjust only those controls that are covered by the operating instructions as an improper adjustment of other controls may result in damage and will often require extensive work by a qualified technician to restore the product to its normal operation.
 - e) if the product has been dropped or damaged in any way.
 - f) when the product exhibits a distinct change in performance – this indicates a need for service.
- 21) **Replacement Parts** — When replacement parts are required, be sure the service technician has used replacement parts specified by the manufacturer or have the same characteristics as the original part. Unauthorized substitutions may result in fire, electric shock, or other hazards.
- 22) **Safety Check** — Upon completion of any service or repairs to this product, ask the service technician to perform safety checks to determine that the product is in proper operating condition.
- 23) **Wall or Ceiling Mounting** — The product should be mounted to a wall or ceiling only as recommended by the manufacturer.
- 24) **Heat** — The product should be situated away from heat sources such as radiators, heat registers, stoves, or other products (including amplifiers) that produce heat.

Section 1 : Introduction

Thank you for purchasing the TASCAM DA-302. To meet the requirements of professional applications, the DA-302 is provided with the following functions.

- A variety of dubbing modes (normal/high speed/program/append)
- Dual recording
- Continuous recording/playback (with more than one deck) possible
- Tape duplication using more than one deck
- Subcode data recording/editing

Before using your new deck, read this manual over carefully to be sure that you understand how to operate it correctly and know how to take advantage of its many functions. After reading this manual, keep it on hand for future reference.

Table of Contents

Important Safety Precautions	2	7-2-1. Recording the Start ID automatically	20
Safety Instructions	3	7-2-2. Recording the Start ID manually	20
Section 1 : Introduction	4	7-2-3. Erasing the Start ID	21
1-1. Configuration	5	7-3. Skip ID	21
1-2. Memory backup	5	7-3-1. Recording the Skip ID	21
1-3. Installation and operation precautions	5	7-3-2. Erasing the Skip ID	22
1-4. Condensation	5	7-4. End ID	22
Section 2 : DAT cassettes	6	7-4-1. Recording the End ID	22
2-1. Structure of a DAT cassette	6	7-4-2. Erasing the End ID	22
2-2. Loading a DAT cassette	6	7-5. Program numbers	22
Section 3 : Block diagram	7	7-5-1. Recording the program number	22
Section 4 : Features and controls	9	7-5-2. Erasing the program number	22
4-1. Front panel	10	7-5-3. Renumber	22
4-2. Rear panel	13	7-6. ABS time	23
4-3. RC-D302 remote control unit	14	7-7. Program time	23
Section 5 : Recording	15	Section 8 : Convenient functions	24
5-1. Normal recording	15	8-1. Rec muting	24
5-1-1. Recording analog input signals	15	8-2. Skip search	24
5-1-2. Recording digital input signals	15	8-3. Direct search	24
5-2. Dubbing	16	8-4. Locating function	24
5-2-1. Making an identical tape including		8-4-1. Setting the memo point	24
subcodes	16	8-4-2. Correcting the memo point	24
5-2-2. Dubbing a tape from the middle	16	8-4-3. Locating a memo point	24
5-2-3. Making a tape with the program order		8-5. Blank search	25
changed	16	Section 9 : Using more than one DA-302	26
5-3. Dual recording	17	9-1. Continuous recording with more than	
5-4. Continuous recording	17	one DA-302	26
Section 6 : Playback	18	9-2. Duplicating	27
6-1. Normal playback	18	9-3. Continuous playback with more than	
6-2. Continuous playback	18	one DA-302	27
6-3. Skip playback	18	Section 10 : Menu	28
6-4. Single playback	18	Section 11 : Specifications	30
6-5. Repeat playback	19	Section 12 : Warning Indications and	
6-6. Program playback	19	Error messages	32
Section 7 : Recording/editing of subcode data	20	12-1. Warning Indications during operation	24
7-1. Subcode data	20	12-2. Error Messages	24
7-2. Start ID	20	Section 13 : Optional Accessories	33

1-1. Configuration

This deck consists of the following.

1. DA-302 main unit
2. Accessories
 - Mount screw kit
 - RC-D302 remote control unit
 - Owner's manual

1-2. Memory backup

AUTO ID mode, AUTO ID detection level, memo point and menu setting data are all retained in the DA-302's internal memory even when the power is turned off.

1-3. Installation and operation precautions

- Do not operate this deck when the temperature is outside the operating range of 5°C to 35°C. To prevent malfunctions, do not install this deck anywhere where it could be exposed to dust or subject to high humidity.
- Do not apply excessive force. This could damage the internal circuitry or the cabinet.
- Use a soft cloth (such as a silicone cloth) to clean the cabinet. If the unit is very dirty, wipe the dirt off with a cloth dipped in diluted detergent. Do not use solvents such as thinner and benzine as these can melt plastic or coated surfaces and fade characters inscribed on the panel.
- Because of improvements in design and specifications, the product shown in illustrations in this manual may differ from the actual product.

Rack mounting

Install this deck with the provided mount screw kit as illustrated.

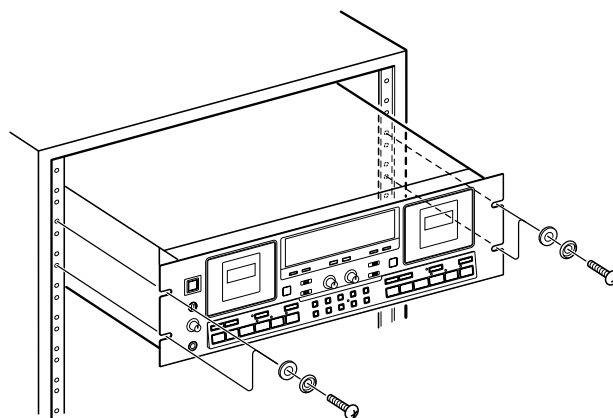

Note:

When mounting this deck in a rack, do not reinstall the mount screws after removing the deck's feet or you may damage PCBs or other internal components. Handle the removed feet carefully.

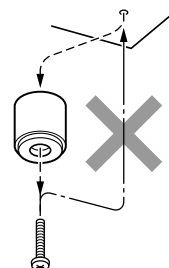

1-4. Condensation

When you move the deck from a cold place to a warm place or use it after a sudden temperature change, condensation may occur. If this happens, leave the power on, but do not operate the deck. After one or two hours, turn the power off and then on again.

For CANADA

AC POWER CORD CONNECTION

CAUTION :
TO PREVENT ELECTRIC SHOCK MATCH WIDE BLADE OF PLUG TO WIDE SLOT, FULLY INSERT.

CORDON DE CONNEXION CA

ATTENTION :
POUR ÉVITER LES CHOCS ÉLECTRIQUES, INTRODUIRE LA LAME LA PLUS LARGE DE LA FICHE DANS LA BORNE CORRESPONDANTE DE LA PRISE ET POUSSER JUSQU' AU FOND.

Section 2 : DAT cassettes

2-1. Structure of a DAT cassette

Top view

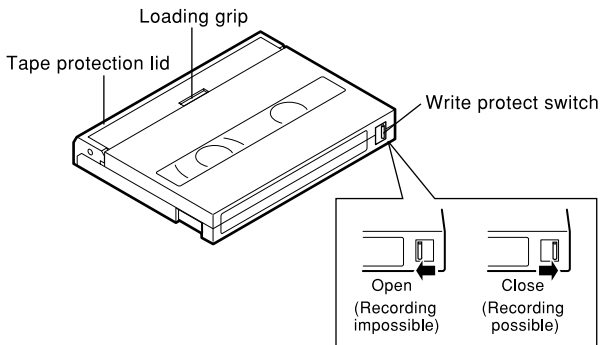

Bottom view

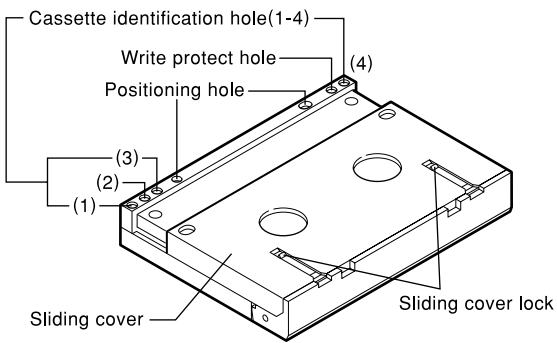

Identification Hole			Signified
1	2	3	
×	×	×	Metal coating or equivalent/ 13 μm tape thickness
×	○	×	Metal coating or equivalent/ Thin tape
×	×	○	1.5 time track pitch/ 13 μm tape thickness
×	○	○	1.5 time track pitch/ Thin tape
○	—	—	(Reserved for auxiliary tape type definitions)

Where: "○" = Open "×" = Closed

- Hole #4 shows "prerecorded" (Open) or not (Closed).
- Dimensions: 73 x 54 x 10.5 mm (W x D x H)
- Tape width: 3.81 mm
- The cassette shells are designed to prevent the tape from being touched directly by hand.

Notes:

- DAT cassettes record and play in one direction only. Do not load DAT cassettes upside down.
- Do not use force to open the tape protection lid and do not pull the tape out and touch it with your fingers.
- Store the DAT cassettes in their plastic cases.
- Do not place DAT cassettes on a television, speaker or near equipment which could generate a magnetic field.

120-minute cassettes or longer (180-min cassette, etc.)

When you use a thin tape (120 minutes or longer), operation and performance may be affected. Thin tapes can also get tangled inside the mechanism. For best results, do not use thin tapes.

2-2. Loading a DAT cassette

- 1 Press the POWER switch to turn the power on.
- 2 Press the EJECT key to open the cassette holder.
- 3 Load a cassette.
- 4 Push the cassette holder to close it.

- When ejecting the cassette, hold both ends of the cassette so as not to prevent the sliding cover from moving back into place.

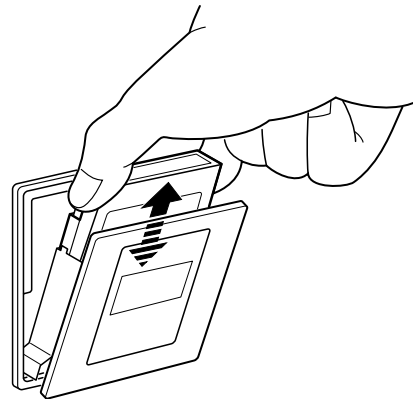

Section 3 : Block Diagram

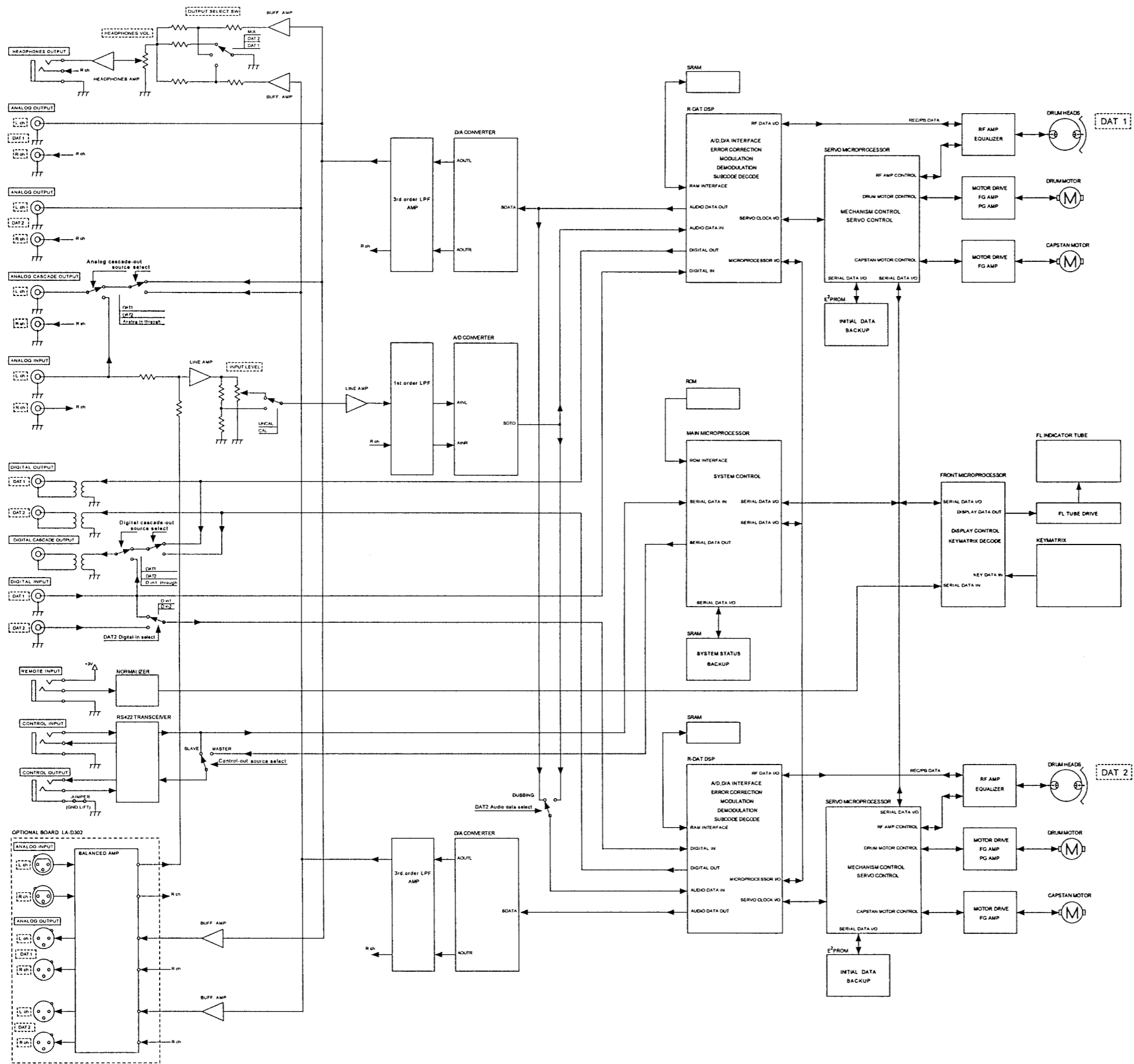

Section 4 : Features and Controls

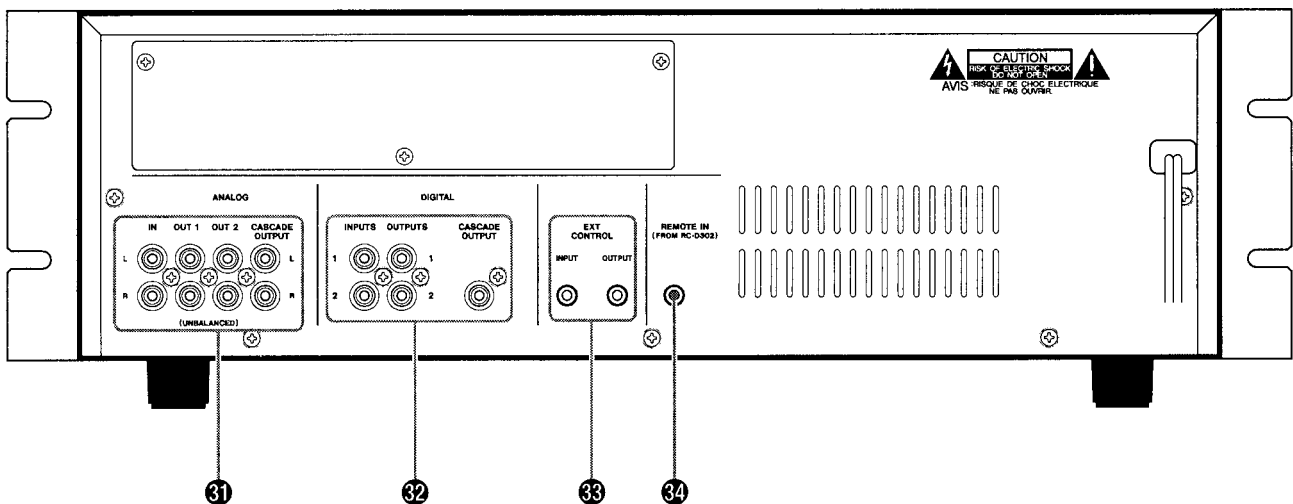
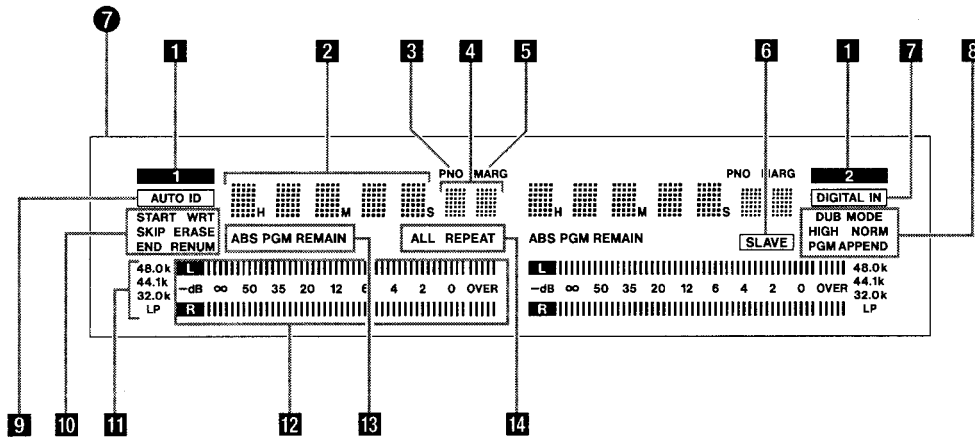
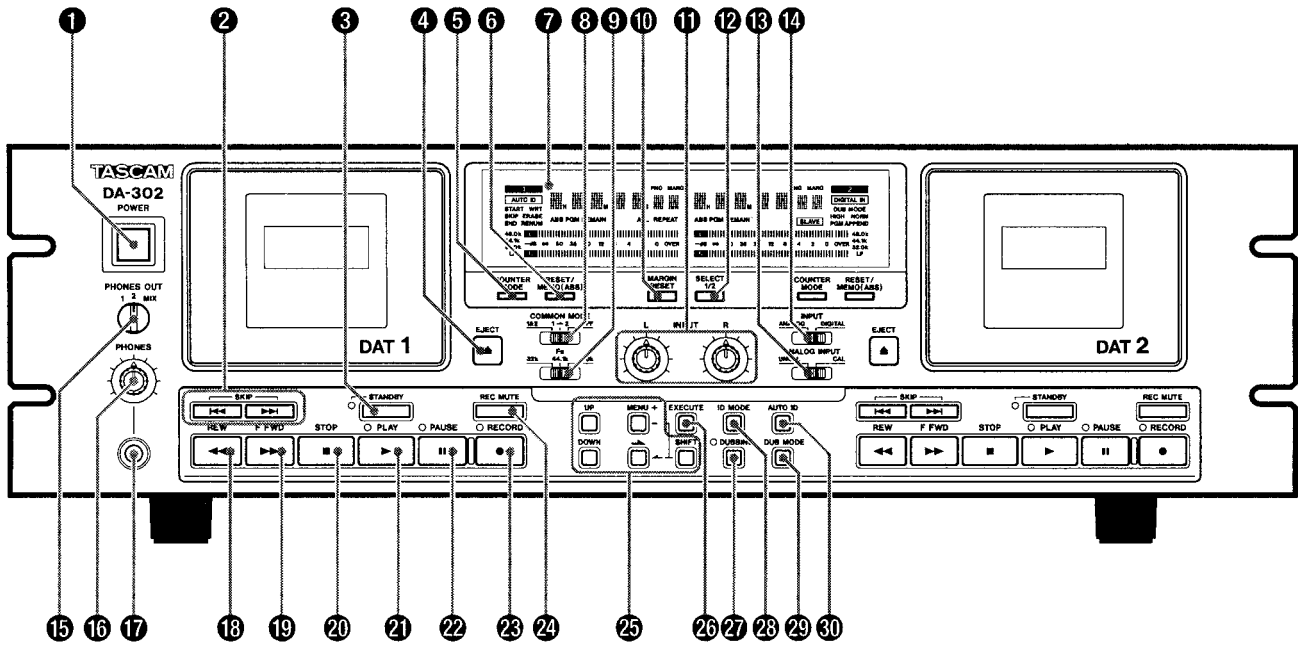

4-1. Front panel

① POWER switch

② SKIP keys

For skip search. (☞ p.24)

③ STANDBY key

With this key ON (LED lit), the Play-Pause mode is automatically engaged after skip search, direct search, or location search.

④ EJECT key

Press to load or unload the cassette.

⑤ COUNTER MODE key

To switch the time mode on the time display. Each time this key is pressed, the mode changes in the following order.

ABS time → PGM time → REMAIN time →
Tape counter

● ABS (absolute) time:

Shows the elapsed (absolute) time from the beginning of the tape up to the current position in hours, minutes and seconds.

■ In the Long Play mode, the displayed time differs from the actual time. Double the displayed time to get the actual time.

● PGM (program) time:

Shows the elapsed time from the beginning of each program (start ID) in hours, minutes and seconds.

● REMAIN time:

Shows the tape remaining time.

■ If a "TOC (Table Of Contents)" is written on the tape (such as a commercially-available music tape), the remaining time is shown in hours, minutes and seconds. If there is no "TOC", the time is shown in hours and minutes.

■ When "- -- --" is displayed, it means that the remaining time is being calculated. Once the calculation is complete, the time is shown.

■ In the Long Play mode, the displayed time differs from the actual time. Double the displayed time to get the actual time.

● Tape counter:

Counts according to the tape running.

■ When the "Dig Out" menu is set to "AES/EBU" (☞ p.28), time code is shown if it is written on the tape.

⑥ RESET/MEMO (ABS) key

● When pressed with the counter mode set to Tape Counter, the counter value is reset to "00 00".

● When pressed with the counter mode set to ABS, the current tape position point is stored in memory for later direct access.

⑦ Display

Displays different information regarding the unit's status. The information displayed varies according to the mode.

① 1, 2

Shows the deck selected by the SELECT 1/2 key.

② Time display

Time selected by the COUNTER MODE key is shown. Also, menu contents are shown.

③ PNO

Lights when the program number is shown in the program number/margin display.

④ Program number/margin display

● When performing recording/rec-pause/sampling monitor, or when the MARGIN RESET key is pressed during playback, a margin value is shown. The margin to the full scale level is shown in the range 0 dB to 39 dB. Until the MARGIN RESET key is pressed, the margin value for the input signal at maximum is maintained. If the margin value exceeds the full scale level, 0 blinks.

● In cases than those above, the program number is shown.

⑤ MARG

Lights when the margin value is shown in the program number/margin display.

⑥ SLAVE

If more than one DA-302 is connected, and this deck is set to SLAVE, this indicator lights.

⑦ DIGITAL IN

Lights when "DIGITAL" is selected with the INPUT switch.

⑧ Dubbing mode display

DUB MODE HIGH:

Lights in the High-Speed Dubbing mode.

DUB MODE NORM:

Lights in the Normal-Speed Dubbing mode.

DUB MODE PGM:

Lights in the Program Dubbing mode.

DUB MODE APPEND:

Lights in the Append Dubbing mode.

⑨ AUDIO ID

Lights when the Start ID Auto Writing mode is selected.

10 ID-related display

Shows the indication for the deck selected by the SELECT 1/2 key.

START WRT:

Lights when the Start ID Manual Writing mode is selected.

START ERASE:

Lights when Start ID erasing is selected.

SKIP WRT:

Lights when Skip ID writing is selected.

SKIP ERASE:

Lights when Skip ID erasing is selected.

END WRT:

Lights when End ID writing is selected.

RENUM:

Lights when renumbering is selected.

START:

Lights when the Start ID is detected.

SKIP:

Lights when the Skip ID is detected.

END:

Lights when the End ID is detected.

11 Sampling frequency display

- When an analog signal is being recorded, the sampling frequency (48.0k, 44.1k, 32.0k) selected by the Fs switch is lit.
- When a digital signal is being recorded, the sampling frequency (48.0k, 44.1k, 32.0k) of the input signal is lit.
 - When "DIGITAL" is selected with the INPUT switch and recording is performed without digital signal input, 48.0k blinks.
- LP lights in the Long Play mode.

12 Peak level meter

- Shows the input signal level during recording/record-pause/sampling monitor.
- The playback signal level is shown during playback.
- When the input or playback signal level surpasses the full-scale level, the OVER section lights.

13 Time-related display

ABS:

Lights when the ABS time is shown on the time display.

PGM:

Lights when the PGM time is shown on the time display.

REMAIN:

Lights when the REMAIN time is shown on the time display.

14 Repeat display

Shows the indication for the deck selected by the SELECT 1/2 key.

REPEAT:

Lights in the One-Program Repeat mode.

ALL REPEAT:

Lights in the All-Program Repeat mode.

8 COMMON MODE switch

1 & 2:

Select to engage both Deck 1 and Deck 2 in the Record or Play mode at the same time.

1 → 2:

Continuous playback or recording on Deck 1 and Deck 2.

OFF:

For independent operation of Deck 1 and Deck 2.

9 Fs switch

- When recording analog input signals, select the sampling frequency (32k, 44.1k, 48k).
 - When 32k is selected, the Long Play mode is engaged.
 - When recording digital input signals, the sampling frequency is automatically determined according to the input signals.

10 MARGIN RESET key

- Resets the margin value when pressed while the margin value is shown in the program number/margin display.
 - When holding this key pressed, the margin value corresponding to each input signal is shown continuously.
- Shows the margin value for as long as it is pressed, when pressed while the program number is shown in the program number/margin display during playback.

11 INPUT level controls

Use to adjust the recording level.

12 SELECT 1/2 key

To select the control deck for Deck 1 and Deck 2 (ID MODE key, EXECUTE key).

When setting the menu, use to select the deck as required.

13 ANALOG INPUT switch

Set this switch when input signals are analog.

UNCAL:

To adjust the recording level with the INPUT level controls.

CAL:

The input and output levels are fixed and the recording level cannot be adjusted.

- For the specified input level, the level meter shows -16 dB.

14 INPUT switch

Set this switch according to input signals.

ANALOG:

Select when input signals are analog.

DIGITAL:

Select when input signals are digital.

15 PHONES OUT switch

1 (2):

Outputs Deck 1 (Deck 2) playback signals from the PHONES jack.

- Outputs input signals when performing recording/record-pause/sampling monitor.

MIX:

Outputs mixed playback signals from both Deck 1 and Deck 2.

16 PHONES control

Adjusts PHONES jack signal output level.

17 PHONES jack

Connect stereo headphones.

18 REW key

To rewind the tape.

- When pressed during playback, 2 times or 4 times normal speed reverse cueing takes place. (☞ p.18)

19 F FWD key

To fast forward the tape.

- When pressed during playback, 3 times or 6 times normal speed forward cueing takes place. (☞ p.18)

20 STOP key

To stop the tape running.

21 PLAY key

To play back the tape. (LED lights.)

22 PAUSE key

Temporarily stops the tape during recording or playback. (LED lights.) To resume recording or playback, press the PLAY key.

- Engages the Play-Pause mode when pressed in the Stop mode.
- Engages the Record-Pause mode when pressed together with the RECORD key.
- To protect the heads, the Play-Pause mode is automatically released after about 8 minutes and the Stop mode is engaged.
- To protect the heads, the Record-Pause mode is automatically released after about 8 minutes and the Sampling Monitor mode is engaged.

23 RECORD key

- Press together with the PLAY key to start recording. (LED lights.)
- Engages the Sampling Monitor mode when pressed in the Stop mode. (LED lights.)
To release the Sampling Monitor mode, press the STOP key.
- Sampling Monitor mode:
As in the Record-Pause mode, the Sampling Monitor mode allows you to monitor input signals. The difference is that the head drum does not rotate in the Sampling Monitor mode and there is no contact between head and tape.

24 REC MUTE key

Use to mute recording. (☞ p.24)

25 Menu-related key

Use to show the menu or to change the menu settings. (☞ p.28)

26 EXECUTE key

Press to write/erase ID of each type.

27 DUBBING key

Press to execute dubbing.

When the dubbing mode is selected with the DUB MODE key, the LED blinks. Pressing this key in this status starts dubbing operation and the LED lights.

28 ID MODE key

Use for writing/erasing ID of each type. (☞ p.20)

29 DUB MODE key

Use to select the Dubbing mode. The selected mode is shown in the display. (☞ p.16)

30 AUTO ID key

Use to automatically write the Start ID. (☞ p.20)

4-2. Rear panel**31 ANALOG (UNBALANCED) connectors****IN (L, R):**

Analog input connectors for Deck 1.

- During dual recording or continuous recording, these connectors are used as the input connectors common for Deck 1 and Deck 2.

OUT 1 (L, R):

Analog output connectors for Deck 1.

OUT 2 (L, R):

Analog output connectors for Deck 2.

CASCADE OUT (L, R):

When more than one DA-302 is used, output analog signals from these connectors. (☞ p.26)

- To select signals for output, refer to "Cas Out" on the menu. (☞ p.28)

32 DIGITAL connectors**INPUTS (1, 2):**

Digital input connectors for Deck 1 and Deck 2.

OUTPUTS (1, 2):

Digital output connectors for Deck 1 and Deck 2.

CASCADE OUT:

When using more than one DA-302, output digital signals from this connector.

- To select signals for output, refer to "Cas Out" on the menu. (☞ p.28)

33 EXT CONTROL connectors

Use when connecting more than one DA-302 using the optional WR-7000 connection cable. (☞ p.26)

34 REMOTE IN connector

Connect the provided RC-D302 remote control unit.

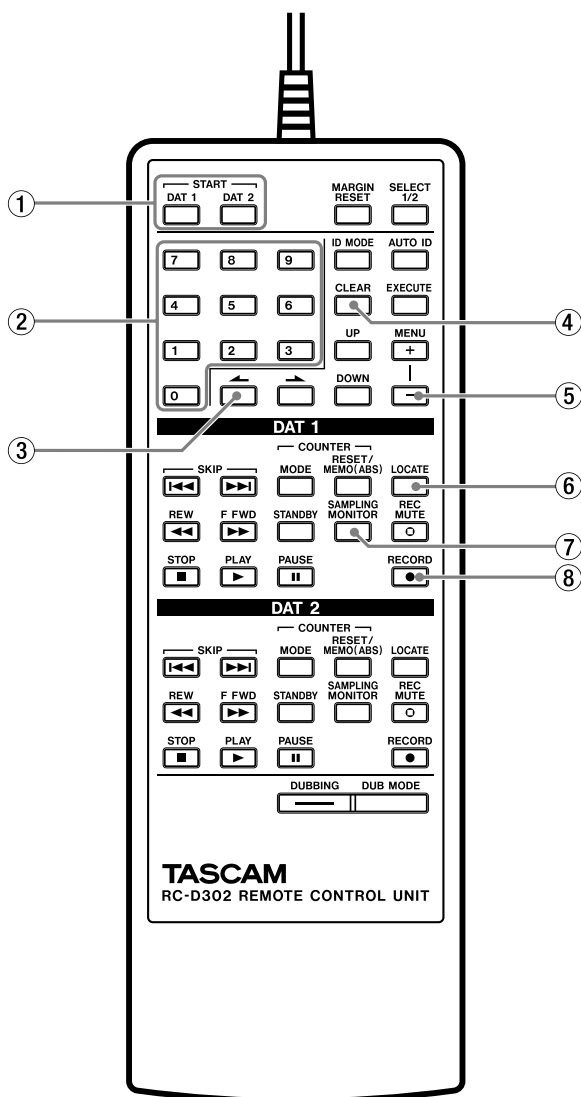

4-3. RC-D302 remote control unit

- ① **START key**
Use to perform direct search play. (☞ p.24)
- ② **Numeric keypad**
Use to directly select the program. (☞ p.24) Also, use to enter the numerical values for memo point.
- ③ **MENU (←) key**
Functions in the same way as when the → key is pressed while pressing the SHIFT key on the main unit.
- ④ **CLEAR key**
When directly selecting the program, use this key to cancel the selected program number or to clear the numeric value for the memo point.
- ⑤ **MENU (-) key**
Functions in the same way as when the MENU key is pressed while pressing the SHIFT key on the main unit.
- ⑥ **LOCATE key**
Locate the tape position at the memo point. (☞ p.24)
- ⑦ **SAMPLING MONITOR key**
Press to engage the Sampling Monitor mode. The same function as when only the RECORD key on the main unit is pressed.
- ⑧ **RECORD key**
The function of this key is different from that of the RECORD key on the main unit. Pressing this key engages the Record-Pause mode.
 - Other keys function in the same way as the corresponding keys on the main unit.

Section 5 : Recording

Note:

Before recording, select Copy ID from the menu. (☞ p.28)

The Copy ID cannot be changed after recording.

5-1. Normal recording

Normal recording means recording on Deck 1 or Deck 2 alone.

However, analog input signals can be recorded only on Deck 1. Recording analog input signals on Deck 2 is not possible.

- When recording on a new blank tape, record a lead-in mark before starting recording.

5-1-1. Recording analog input signals

- 1** Set the COMMON MODE switch to OFF.
- 2** Connect the source to the ANALOG IN connectors.
- 3** Set the INPUT switch to ANALOG.
- 4** Select the sampling frequency (32k, 44.1k, 48k) with the Fs switch.
 - When 32k is selected, the Long Play mode is engaged.
- 5** Press the RECORD key to engage the Sampling Monitor mode.
 - When using the remote control unit, press the SAMPLING MONITOR key.
- 6** Adjust the input signal level with the INPUT level control.
 - When the ANALOG INPUT switch is set to CAL, the input and output level is fixed. It is preset at the factory so that the level meter shows -16 dB for the specified input level of -10 dBV. To adjust the recording level, set this switch to UNCAL.
- 7** Pressing the PLAY key while pressing the RECORD key starts recording.

5-1-2. Recording digital input signals

- 1** Set the COMMON MODE switch to OFF.
- 2** Connect the source to the DIGITAL IN connector for the Deck 1 (Deck 2).
- 3** Set the INPUT switch to DIGITAL.
- 4** Pressing the PLAY key while pressing the RECORD key of Deck 1 (Deck 2) starts recording.
 - When performing digital-to-digital copy from a DAT deck or a CD player, set the detection level to "dd" in the AUTO ID mode to record the Start ID and Skip ID (DAT only) at the same time. (☞ p.20)

Recording lead-in mark

When recording on a non-recorded tape, it is necessary to record a lead-in mark. The lead-in mark is an area where no signal is recorded and should be recorded at the start of the tape so that the start of a program is not clipped during recording or playback.

- (1) Rewind the tape to the beginning of the tape with the REW key.
- (2) Press the PAUSE key while pressing the RECORD key. The lead-in mark is automatically recorded, then the Record-Pause mode is engaged.

- With non-recorded tapes, this operation is performed automatically even if recording is started without performing operation (2). When recording a source from which audio signals are input immediately after recording starts, be sure to perform the above operations before starting recording.
- When you rewind a tape on which a lead-in mark has been recorded, the lead-in mark is played back automatically, then the tape stops. While the lead-in mark is played back, "BB" is shown in the program number display.

5-2. Dubbing

Dubbing means copying audio signals from Deck 1 to Deck 2.

- The playback sound during dubbing is output from the ANALOG OUT and DIGITAL OUT connectors for Deck 1 and Deck 2.
 - For high-speed dubbing, signals are not output to the DIGITAL OUT connectors.
When high-speed dubbing is performed for a tape recorded in the Long Play mode, no signal is output to the ANALOG OUT connector as well.

5-2-1. Making an identical tape including sub-codes

- 1** Load the source tape in Deck 1 and the recording tape in Deck 2.
 - 2** Set the COMMON MODE switch to OFF.
 - 3** Select the Dubbing mode with the DUB MODE key.
 - For dubbing at high speed (2 times normal speed), select DUB MODE HIGH and for dubbing at normal speed, select DUB MODE NORM.
 - A tape recorded in the Long Play mode can be dubbed at high speed (4 times normal speed).
 - 4** When the DUBBING key is pressed, the tapes in Deck 1 and Deck 2 are rewound, then dubbing starts.
- To stop dubbing in the middle, press the STOP key on Deck 1 or Deck 2.

5-2-2. Dubbing a tape from the middle

- 1** Set the COMMON MODE switch to OFF.
- 2** Select the DUB MODE APPEND with the DUB MODE key.
- 3** Press the DUBBING key to start dubbing from that point.

5-2-3. Making a tape with the program order changed

- 1** Set the COMMON MODE switch to OFF.
 - 2** Select Deck 1 with the SELECT 1/2 key.
 - 3** Follow the procedure in "6.6 Program playback" to select the programs to be dubbed.
 - 4** Set the Dubbing mode to DUB MODE PGM with the DUB MODE key.
 - 5** Pressing the DUBBING key rewinds the tape in Deck 2 to the beginning of the tape, then starts dubbing according to the program.
- To stop dubbing in the middle, press the STOP key on Deck 1 or Deck 2.
 - When the AUTO ID mode is engaged, a Start ID is automatically recorded at the start of each program to be recorded.

5-3. Dual recording

Dual recording means recording the same input source on both Deck 1 and Deck 2.

- 1** Connect the input source to the ANALOG IN connectors if it is analog and to the DIGITAL IN "1" connector if it is digital.
 - Connecting it to the DIGITAL "2" connector is invalid.
 - 2** Set the COMMON MODE switch to "1&2".
 - 3** For analog input signals, follow procedures 3 to 6 in "5-1-1. Recording analog input signals". For digital input signals, set the INPUT switch to DIGITAL.
 - 4** When Deck 1 is set in the Record mode, recording starts on both Deck 1 and Deck 2 simultaneously.
 - 5** When the Stop key on Deck 1 is pressed, recording on both Deck 1 and Deck 2 stops simultaneously.
- When the COMMON MODE switch is set to "1&2", the STOP key, PLAY key, PAUSE key, RECORD key, F FWD key, REW key and REC MUTE key on Deck 1 (Deck 2) are effective for both decks.
 - The input signals during recording are output from the ANALOG OUT connectors and the DIGITAL OUT connector of Deck 1 and Deck 2.

5-4. Continuous recording

Continuous recording means recording one input source continuously using tapes in Deck 1 and Deck 2.

- 1** Connect the input source to the ANALOG IN connectors for analog input signals and to the DIGITAL IN "1" connector for digital signals.
 - The DIGITAL IN "2" connector is disabled.
 - 2** Set the COMMON MODE switch to "1 → 2".
 - 3** For analog input signals, follow procedures 3 to 6 in "5-1-1. Recording analog input signals". For digital input signals, set the INPUT switch to DIGITAL.
 - 4** Set "Seqtime" in the menu. (☞ p.28)
 - 5** Set Deck 1 in the Record mode and start recording. When the ABS time of Deck 1 reaches the time set with "Seqtime", Deck 2 automatically starts recording.
 - 6** Deck 1 rewinds the tape automatically to the beginning either 3 minutes after the time set with "Seqtime" or when the tape end is reached.
 - 7** Deck 2 rewinds the tape automatically to the beginning either 3 minutes after the time set with "Seqtime" or when the tape end is reached.
- To stop recording in the middle, press the STOP key on the deck which is recording.
 - The input signals being recorded are output from the ANALOG OUT connectors and DIGITAL OUT connector of Deck 1 (Deck 2).

Section 6 : Playback

6-1. Normal playback

- 1 Set the COMMON MODE switch to OFF.
 - 2 Press the PLAY key to start playback.
- When the REW key (F FWD key) is pressed during playback, 2 times (3 times) normal speed rewind cueing (fast-forward cueing) is performed. Pressing it once more allows 4 times (6 times) normal speed cueing. Pressing it once more restores 2 times (3 times) cueing. To restore normal playback, press the PLAY key.
 - Holding the REW key (F FWD key) pressed for 1 second or more during playback performs 2 times (3 times) normal speed rewind (fast forward) cueing for as long as the key is pressed. Releasing it restores normal playback.
 - Pressing the REW key during fast-forward cueing switches to 2 times normal speed rewind cueing.
 - Pressing the F FWD key during rewind cueing switches to 3 times normal speed fast-forward cueing .
 - Playback signals are output from the ANALOG OUT and DIGITAL OUT connectors of Deck 1 (Deck 2).

6-2. Continuous playback

With continuous playback, the tapes in Deck 1 and Deck 2 are played back continuously.

- 1 Set the COMMON MODE switch to "1 ➔ 2".
 - 2 Set "Seqtime" in the menu. (☞ p.28)
 - 3 Press the PLAY key on Deck 1 to start playback. When the ABS time of Deck 1 reaches the time set with "Seqtime", Deck 2 starts playback automatically.
 - 4 Deck 1 automatically rewinds the tape to the beginning either 3 minutes after the time set with "Seqtime" or when the tape end is reached.
 - 5 Deck 2 automatically rewinds the tape to the beginning either 3 minutes after the time set with "Seqtime" or when the tape end is reached.
- The playback signals are output from the ANALOG OUT and DIGITAL OUT connectors of Deck 1 (Deck 2).

- The playback sound can also be monitored through the ANALOG CASCADE OUTPUT connectors. When "Cas Out" is set to "Auto" in the menu (☞ p.28), playback sound output is switched from Deck 1 to Deck 2 at the time Deck 2 starts playback. In this status, if the PLAY key of Deck 1 is pressed, you can monitor the playback sound of Deck 1 again.

6-3. Skip playback

When a Skip ID is detected during playback, the tape is fast-forwarded to the next Start ID and resumes playback.

- 1 Select the deck with the SELECT 1/2 key.
 - 2 Press the MENU key to show the following menu in the time display.

```
Skip1 Off
```
 - 3 Set to "On" with the UP/DOWN key to engage the Skip Play mode.
- If the STANDBY key is set to ON, the Play-Pause mode is engaged at the Start ID.

6-4. Single playback

When a Start ID is detected during playback, this function automatically engages the Play-Pause mode.

- 1 Select the deck with the SELECT 1/2 key.
- 2 Press the MENU key to show the following message in the time display.

```
Single1 Off
```
- 3 Set to "On" with the UP/DOWN key to engage the Single Play mode.

6-5. Repeat playback

This function allows one or all programs to be played back repeatedly.

- With one program repeat, the tape is automatically rewound to the previous Start ID when a Start ID is detected.
- For all program repeat, the tape is automatically rewound to the beginning when the tape end is reached or the End ID is detected.

1 Select the deck with the SELECT 1/2 key.

2 Press the MENU key to show the following menu in the time display.

```
Repeat  Off
```

3 Set to "Single" with the UP/DOWN key to engage the One Program Repeat mode. Set to "All" to engage the All Program Repeat mode.

- If the STANDBY key is set to ON in the One Program Repeat mode, the Play-Pause mode is engaged at the beginning of the program after one program has been played.

6-6. Program playback

This function allows you to play back programs in a user-specified sequence.

1 Select the deck with the SELECT 1/2 key.

2 Press the MENU key to show the following menu in the time display.

```
PGM1    s01_EE
```

3 Enter the program number of the program you want to play first with the UP/DOWN key.

```
PGM1    s01_03
```

4 To program the program you want to play back second, first press the \rightarrow key and set the step number to "s02".

```
PGM1    s02_EE
```

5 Enter the program number of the program you want to play back second with the UP/DOWN key.

```
PGM1    s02_05
```

6 Up to 50 programs can be programmed in the same way.

7 Press the EXECUTE key to start Program Playback.

- The last step is the step before the step in which "EE" is shown in the program number input section on the menu.

e.g.) In case of [PGM1 s03_EE], step 02 (s02) is the last step.

- Checking the programmed sequence

Each time the \rightarrow key is pressed while the program menu (e.g.: [PGM1 s01_03]) is displayed, the step number changes, allowing you to check the program number.

(By pressing the \rightarrow key while pressing the SHIFT key, you can check the previous step number.)

- Adding to or changing the programmed sequence

To add a program number, display the step number with "EE" and enter the program number. Adding a program number in the middle of the program sequence is not possible.

To change the program number, display the program number to be changed by pressing the \rightarrow key and enter a new program number with the UP/DOWN key.

- To enter "EE", press the UP key and DOWN key simultaneously or the CLEAR key on the remote control unit.

Section 7 : Recording/editing of subcode data

7-1. Subcode data

Recordable subcode data is shown below.

- Start ID (recording time: 9 seconds*)
- Skip ID (recording time: 1 second*)
- End ID (recording time: 9 seconds*)
- Program number (recording time: 9 seconds*)
- ABS time
- Program time (recording time: 9 seconds*)

* Standard mode. Long Play recording time is twice that in the Standard mode.

7-2. Start ID

A Start ID is code recorded at the beginning of each newly recorded program and is used to locate the beginning of that program during search. Start IDs can be recorded automatically or manually.

Note:

Be sure to leave at least 9 seconds between Start IDs. If the time between Start IDs is less than 9 seconds, a malfunction may occur during search. It is recommended to leave 30 seconds or more to ensure proper operation.

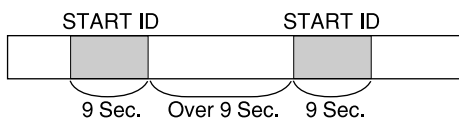

7-2-1. Recording the Start ID automatically

Press the AUTO ID key; "AUTO ID" lights in the display and the Auto Recording mode is engaged.

- When the AUTO ID key is pressed, the detection level is shown for about 1 second in the time display (initial setting is -48 dB).
- To release the Auto Recording mode, press the AUTO ID key again.
- Start IDs are recorded in the Auto Recording mode under the following conditions.
 - * A signal exceeding the detection level is input after recording starts
 - * A signal below the detection level continues for 3 or more seconds during recording and is then followed by a signal exceeding the detection level.

- The detection level can be adjusted to suit the recording source.

- (1) While holding the SHIFT key pressed, press the AUTO ID key as many times as necessary to select the desired level (-36 dB, -42 dB, -48 dB, -54 dB, dd*).
- (2) Release the SHIFT key to determine the level.

- * When "dd" is selected, the ID is recorded by using information from the digital signal interface (SPDIF) input from the digital input connector.
 - When a DAT deck is connected to the digital input connector, Start IDs and Skip IDs are recorded corresponding to the Start IDs and Skip IDs recorded on the DAT.
 - When a CD player is connected to the digital input connector, Start IDs are recorded corresponding to the track numbers on the CD.
 - When a unit other than a DAT deck or a CD player is connected to the digital input connector or analog input connectors, the "-54 dB" setting is used.

7-2-2. Recording the Start ID manually

- Manual recording on the fly

- 1** Select the deck with the SELECT 1/2 key.
- 2** Press the ID MODE key so the "START WRT" lights in the display.
- 3** During recording or playback, press the EXECUTE key at the desired position to record the Start ID. The "START WRT" blinks and the Start ID is recorded for 9 seconds from that point.
 - When the COMMON MODE switch is set to "1&2", the Start ID is recorded on tapes in both Deck 1 and Deck 2 regardless of the setting of the SELECT 1/2 key.

- Manual recording with menu

- 1** Select the deck with the SELECT 1/2.
- 2** Press the ID MODE key so that the "START WRT" lights in the display.
- 3** Press the MENU key to show the following menu in the time display.

Pos 1 ---H ---M ---S ---

- 4** Press the RESET key during playback to capture the ABS time at that time. The time is shown in hours, minutes, seconds and frames in the time display. The deck enters the Play-Pause mode.

Pos 1 0h 13m 45s 14

5 When the PLAY key is pressed, playback takes place for about 3 seconds from the captured ABS time. Then, the Play-Pause mode is engaged.

- In this status, press the UP and DOWN keys simultaneously or press the CLEAR key on the remote control unit to restore the condition in step 3.

6 Each time the UP key or DOWN key is pressed in the Play-Pause mode, the captured ABS time can be changed by +5 frames or -5 frames (up to ±2 seconds).

```
Pos 11  0H 13M 45s 09
```

↑ DOWN key

```
Pos 11  0H 13M 45s 14
```

↓ UP key

```
Pos 11  0H 13M 45s 19
```

7 Repeat steps 5 and 6 to set the desired point, then press the EXECUTE key. The Start ID is recorded from that point.

7.2.3 Erasing the Start ID

- 1** Select the deck with the SELECT 1/2.
- 2** Press the ID MODE key so that "START ERASE" lights in the display.
- 3** In the Stop or Play mode, press the EXECUTE key. The tape is rewound to the previous Start ID and this Start ID is erased while it is being played. During erasing, the "START ERASE" blinks and when erasing is complete, the normal playback is restored.

7-3. Skip ID

Skip IDs are recorded to enable skip playback (☞ p.18).

7-3-1. Recording the Skip ID

• Recording on the fly

- 1** Select the deck with the SELECT 1/2 key.
- 2** Press the ID MODE key so that the "SKIP WRT" lights on the display.

3 During recording or playback, press the EXECUTE key at the point where you want to record the Skip ID. The "SKIP WRT" blinks and the Skip ID is recorded for one second from that point.

- When the COMMON MODE switch is set to "1&2", the Skip ID is recorded on tapes in both Deck 1 and Deck 2 regardless of the setting of the SELECT 1/2 key.

• Recording with the menu

- 1** Select the deck with the SELECT 1/2 key.
- 2** Press the ID MODE key so that the "SKIP WRT" lights on the display.
- 3** Press the MENU key to show the following menu in the time display.

```
Pos 11  ---H ---M ---S ---
```

4 Press the RESET key during playback to capture the current ABS time. The time is shown in hours, minutes, seconds and frames in the time display. Then, the deck enters the Play-Pause mode.

```
Pos 11  0H 13M 45s 14
```

5 Press the PLAY key to play back the tape from the captured ABS time for about 3 seconds. Then the Play-Pause mode is engaged.

- In this status, press the UP and DOWN keys simultaneously or press the CLEAR key on the remote control unit to restore the condition in step 3.

6 Each time the UP or DOWN key is pressed in the Play-Pause mode, the captured ABS time is changed by +5 or -5 frames (up to ±2 seconds).

```
Pos 11  0H 13M 45s 09
```

↑ DOWN key

```
Pos 11  0H 13M 45s 14
```

↓ UP key

```
Pos 11  0H 13M 45s 19
```

Section 7 : Recording/editing of subcode data

- 7 Repeat steps 5 and 6 and when you determine the desired point, press the EXECUTE key. From that point, the Skip ID is recorded.

7-3-2 Erasing the Skip ID

- 1 Press the SELECT 1/2 key to select the deck.
- 2 Press the ID MODE key so that the "SKIP ERASE" lights in the display.
- 3 During stop or playback, press the EXECUTE key. The tape is rewound to the previous Skip ID and the Skip ID is erased while it is played back. During erasing, the "SKIP ERASE" blinks and when the Skip ID has been erased, the normal playback is restored.

7-4. End ID

The End ID marks the tape end position.

The point where the End ID is recorded is detected as the tape end position and the tape cannot be advanced from that point.

When the End ID is detected in the Fast Forward mode, the tape is rewound to the beginning of the End ID and stops for further recording.

When the End ID is detected during playback, the tape is rewound to the beginning of the tape.

- When the End ID is detected, the "EE" lights in the program number display.

7-4-1. Recording the End ID

- 1 Press the SELECT 1/2 key to select the deck.
- 2 In the Record-Pause or Record mode, press the ID MODE key so that the "END WRT" lights.
- 3 In the Record or Record-Pause mode, press the EXECUTE key at the point where you want to record the End ID. The "END WRT" blinks and the End ID is recorded for 9 seconds from that point. After recording, the tape is rewound to the beginning of the End ID and stops.
 - When the COMMON MODE switch is set to "1&2", the End ID is recorded on tapes in both Deck 1 and Deck 2 regardless of the setting of the SELECT 1/2 key.

7-4-2. Erasing the End ID

When the tape is fast-forwarded by pressing the F FWD key, the tape stops at the beginning of the End ID. Recording from that point erases the End ID.

7-5. Program numbers

The program number shows the number of the program and is recorded with the Start ID at the beginning of each program.

7-5-1. Recording the program number

Program numbers are automatically recorded at the same time as Start IDs.

When recording is performed from the beginning of the tape and Start IDs are automatically recorded, program numbers are recorded in order from 01.

- When recording on a tape on which program numbers have already been recorded, first play back the tape so that the program number is shown in the display then record the Start ID.

If the program number is not shown in the display and the Start ID is recorded, the program number is not recorded.

7-5-2. Erasing the program number

When the Start ID is erased, the program number is automatically erased.

7-5-3. Renumber

Renumber means renumbering from the first Start ID as Program 01. Do this when the program numbers have not been recorded correctly because a Start ID has been erased or a new program has been inserted.

- 1 Press the SELECT 1/2 key to select the deck.
- 2 Press the ID MODE key so that the "RENUM" lights in the display.
- 3 Press the EXECUTE key during stop or playback. The tape automatically rewinds to the beginning. When the first Start ID is detected, the program number is recorded. After recording, the tape is advanced to the next Start ID and the program number is recorded in the same way. Thus, the program numbers are recorded in order from 01. When the tape end or the End ID is detected, the tape is rewound to the beginning and stops.

7-6. ABS time

The ABS time is the elapsed time (absolute time) from the beginning of the tape.

When recording is performed from the beginning of the tape, the ABS time is automatically recorded.

- When recording is performed from a point other than the beginning of the tape, ABS time is not recorded.
- Even with a tape on which the ABS time has been recorded, ABS time is not recorded if recording starts from a non-recorded section.
- When recording continuously on a tape with the ABS time recorded, fast forward the tape to the End ID or execute Blank Search (☞ p.25) to wind the tape to the point just before a non-recorded section, then start recording. This ensures that the ABS time is recorded continuously.

7-7. Program time

The program time means the elapsed time from the beginning of each program (Start ID).

The program time is recorded with the Start ID for 9 seconds in the same way as the program number.

When the Start ID is erased, the program time is erased at the same time.

- The program time is recorded for 9 seconds. However, when the part after that is played back, the program time is shown using internal counting.

Section 8 : Convenient functions

8-1. Rec muting

When the REC MUTE key is pressed during recording, no signals are recorded for about 4 seconds and the Record-Pause mode is engaged.

- If the REC MUTE key has been held for 4 seconds or more, releasing the key engages the Record-Pause mode.

8-2. Skip search

This function lets you search for a Start ID.

- 1** When the **⏮** key is pressed once in the Stop/Play-Pause/Play mode, the previous Start ID is searched. If the **⏭** key is pressed, the next Start ID is searched. After the search is complete, tape playback starts.
 - 2** To search other Start IDs, simply press the **⏮** or **⏭** key as many times as required.
 - The number of times you have pressed the key is shown in the program number display.
- If the STANDBY key is set to ON, the Play-Pause mode is engaged after search.

8-3. Direct search

This function searches for a specific program number and plays back the corresponding program. This function can be used only with the remote control unit.

- 1** In the Stop/Play-Pause/Play mode, press the program number with the numeric keypad. The specified program number blinks in the program number display.
 - If you press the wrong program number, press the CLEAR key to re-enter the program number.
 - 2** Pressing the START key starts playback after search.
- If the STANDBY key is set to ON, the Play-Pause mode is engaged after search.

8-4. Locating function

This allows you to set a memo point (one point) based on the ABS time. You can access this point directly with the Locate function.

8-4-1. Setting the memo point

- 1** Press the COUNTER MODE key to set the time mode to ABS time.
 - 2** Press the RESET/MEMO (ABS) key at the point where you want to set the memo point. That point is stored in memory.
 - Setting is possible in any tape running mode.
- When a new memo point is set, the previous memo point is erased.

8-4-2. Correcting the memo point

- 1** Press the SELECT 1/2 key to select the deck.
- 2** Press the MENU key to show the following menu in the time display. The set memo point is shown.

Memo1 0_H05_M42_S

- 3** Pressing the UP/DOWN key allows you to change the memo point second by second.
 - Press the UP and DOWN keys simultaneously or the CLEAR key on the remote control unit to clear the memo point.
After clearing the memo point, you can enter numerical values with the numeric keypad on the remote control unit.

8-4-3. Locating a memo point

Press the PLAY key while pressing the STOP key in the Stop mode. The memo point is located and playback starts.

- When using the remote control unit, press the LOCATE key.
- If the STANDBY key is set to ON, the Play-Pause mode is engaged after the memo point has been located.

8-5. Blank search

To search a non-recorded section on a recorded tape, simply press the F FWD key. When the non-recorded section is detected, the tape is rewound to the point just before the non-recorded section and stops.

If the ABS time is recorded, the ABS time can be recorded continuously from this non-recorded section when recording starts.

- When an END ID is recorded, the tape stops at the beginning of the End ID.
- When a non-recorded section is detected, "- End -" is shown in the time display.

9-2. Duplicating

One source can be recorded on more than one deck at the same time.

- 1** Connect DA-302s as shown in the figure in "9.1 Continuous recording with more than one DA-302".
 - In this case, the connection marked with ** is not necessary.
 - 2** Set the first DA-302 to Master Deck and the other DA-302s to Slave Deck. Set decks to master/slave deck with "Control" in the menu. (☞ p.28)
 - 3** For all connected DA-302s, perform procedures 2 to 3 in "5.3 Dual recording".
 - 4** Press the REW key on Deck 1 of the master deck to rewind the tapes in all decks to the beginning.
 - 5** When the Record mode is engaged on Deck 1 on the master deck, all decks automatically enter the Record mode.
 - 6** To stop recording, press the STOP key on Deck 1 of the master deck.
- If the COMMON MODE switch is set to "1&2", when the STOP key, PLAY key, PAUSE key, RECORD key, FWD key, REW key or REC MUTE key on Deck 1 or Deck 2 of the master deck is pressed, the command is output to all slave decks.

9-3. Continuous playback with more than one DA-302

Continuous playback on more than one DA-302 is possible beginning with the first deck, then the second deck, and so on.

- 1** Connect DA-302s as shown in the figure in "9.1 Continuous recording with more than one DA-302".
 - 2** Set the first DA-302 to Master Deck and the other DA-302s to Slave Deck. Set decks to master/slave deck with "Control" in the menu. (☞ P.28)
 - 3** For all connected DA-302s, perform procedures 1 to 2 in the "6.2 Continuous playback".
 - 4** Press the REW key on Deck 1 in the master deck to rewind the tapes in Deck 1 in the master deck and the slave decks to the beginning.
 - Only the REW key on Deck 1 of the master deck controls the slave decks.
 - 5** Press the REW key on Deck 2 in the master deck to rewind the tape in Deck 2 in the master deck to the beginning.
 - 6** Press the PLAY key on Deck 1 of the master deck to start playback.
 - When Deck 1 reaches the time set with "Seqtime", Deck 2 starts playback.
 - When Deck 2 reaches the time set with "Seqtime", Deck 1 in the second deck receives the command from the EXT CONTROL IN connector and starts playback. This process continues from deck to deck, enabling continuous playback.
 - This procedure is almost identical to that in "9.1 Continuous recording with more than one DA-302". (The difference being that one is for playback and the other is for recording.) For more details on operation, refer to the example in "9.1 Continuous recording with more than one DA-302".
 - 7** To end the operation in the middle, press the STOP key of the deck which is playing back.
- Each deck which starts playback rewinds the tape automatically to the beginning either 3 minutes after the time set with "Seqtime" or when the tape end is reached.

Section 10 : Menu

You can change or display the settings for each mode in the Menu. The menu is shown in the time display.

The menu consists of two groups. Each group is accessed differently.

The tables below show the types of menus and the corresponding access methods.

- Press the MENU key to switch the menu item. Press the MENU key while pressing the SHIFT key to return to the previous menu item.
- Use the UP/DOWN key to change the settings in the menu.
- Press the COUNTER MODE key to return the menu screen to the normal time display.
- Menu settings are retained even when the power is turned off.

Menu (Group 1)

- In the normal time display mode, press the MENU key to access the following menus.

Menu	Set contents	Factory preset	Page to be referred for details
Skip 1 (2)	Off, On	Off	18
Single 1 (2)	Off, On	Off	18
Repeat 1 (2)	Off, Single, All	Off	19
Memo 1 (2)	ABS time	--H--M--S	24
Posi 1 (2)	ABS time	--H--M--S	20, 21
PGM 1 (2)	Step No. and program No.	s01_EE	19
E----AH E----AH	AH, AB, BH	AH	29
DrumT 1 (2)	xxxx H		29

- 1 (2) in the menu shows the deck selected by the SELECT 1/2 key.

Menu (Group 2)

- In the normal time display mode, press the MENU key while pressing the → key to access the following menus.

Menu	Set contents	Factory preset	Page to be referred for details
Dig Out	SPDIF, AES/EBU	SPDIF	29
Control	Master, Slave	Master	29
Copy ID	Proh, 1gen, Free	Proh	29
Peak	Hold Off, Hold On	Hold On	29
Display	Normal, Bright, Dim	Normal	29
Seqtime	0H 15M 00s ~ 2H 30M 00s	2H 00M 00s	29
Cas Out	Auto, Input	Auto	29
Loop	Off, On	Off	29

Menu Details

- **E - - - - AH E - - - - AH**

Shows the error rate during playback.

- In the "----" section on the left, the error rate for Deck 1 is shown while in the "----" section on the right, that for Deck 2 is shown.

- The section showing AH can be changed with the UP/DOWN key.

With AH display:

Shows the error rate of head A.

With AB display:

Shows the error rate of heads A and B.

With BH display:

Shows the error rate of head B.

- Display example:

When "E0030AH E0100AH" is shown, the error rate of head A in the PCM area is 3×10^{-3} for Deck 1 and 1×10^{-2} for Deck 2.

- **DrumT 1 (2)**

Shows the elapsed drum rotating time since the deck was first used. Use this as a guide for regular maintenance.

- **Dig Out**

Select the digital output signal format, SPDIF (IEC958 TYPE II) or AES/EBU (IEC958 TYPE 1), using the UP/DOWN key.

- **Control**

When using more than one DA-302, set them to master/slave deck with the UP/DOWN key.

- When only one DA-302 is used, set to "Master".

- **Copy ID**

Set the Copy ID with the UP/DOWN key. The Copy ID shows how many generations of digital-to-digital copying (digital recording of digital signals) is possible.

The Copy ID is recorded when recording is carried out.

Proh: The copy prohibit ID (10) is recorded.

1gen: The ID (11) permitting copy up to the first generation is recorded.

Free: The ID (00) permitting copy is recorded.

- For digital-to-digital copying with an SCMS (Serial Copy Management System) deck, see below.

When ID (10) is recorded:

A digital-to-digital copy is impossible.

When ID (11) is recorded:

One digital-to-digital copy is possible.

When ID (00) is recorded:

Multiple-generation digital-to-digital copying is possible.

- **Peak Hold**

Set the peak hold of the level meter to On or Off with the UP/DOWN key.

- When set to On, the peak is held. However, the held peak level is reset if the MARGIN RESET key is pressed.

- **Display**

Select the brightness of the display with the UP/DOWN key.

- **Seqtime**

Sets the start time for Deck 2 operation during continuous recording/playback with the UP/DOWN key. Can be set in 1 minute increments (in 15 minute increments with the \blacktriangleright key) in the range of 0H15M00S to 2H30M00S.

When the ABS time of Deck 1 reaches the set time, Deck 2 starts operation.

When more than one DA-302 is connected for continuous recording/playback, and the ABS time of Deck 2 reaches the set time, the REC or PLAY command is output from the EXT CONTROL OUT connector.

- **Cas Out**

Select the signals output from the CASCADE OUT connector with the UP/DOWN key.

When set to Input:

Signals input to the ANALOG IN connectors are output to the ANALOG CASCADE OUTPUT connector.

Also, signals input to the DIGITAL INPUTS connector for Deck1 are output from the DIGITAL CASCADE connector.

When set to Auto:

When either Deck 1 or Deck 2 plays back the tape, the playback signal is output from the ANALOG CASCADE OUTPUT and DIGITAL CASCADE OUTPUT connectors.

When both Decks 1 and 2 are playing back tapes, the sound from the deck which entered the Play mode most recently is output. To output the sound from another deck, press the PLAY key of another deck in the Play mode.

In other cases, the output signals are the same as that output when set to Input.

- **Loop**

Can be set only for the master deck.

When this is set to "On" with the UP/DOWN key, the master deck starts operation again after the last slave deck finishes the operation for continuous recording/playback using more than one DA-302.

Section 11 : Specifications

Format :	Rotary head digital audio tape deck
Tape Speed :	8.15 mm/sec. (SP: Recording/playback) 12.225 mm/sec. (only for playback) 16.3 mm/sec. (SP: Double speed dubbing, LP: 4 times normal speed dubbing) 4.075 mm/sec. (LP: Recording/playback)
Recording Time :	120 minutes (SP: With a 120-minute tape) 240 minutes (LP: With a 120-minute tape)
Fast Winding/Rewinding Time :	Approx. 60 seconds (with a 120-minute tape)
Channels :	Stereo 2 channels
Quantization :	16-bit linear (SP), 12-bit non-linear (LP)
Error Correction Method :	Doubled Reed Solomon code
Sampling Rates :	48 kHz (recording/playback) 44.1 kHz (recording/playback) 32 kHz (recording/playback)
Emphasis :	50 μ sec./15 μ sec (automatically applied in the Play mode)
Frequency Response :	20 – 20 kHz \pm 0.5 dB (48 kHz/44.1 kHz) 20 – 14.5 kHz \pm 0.8 dB (32 kHz)
S/N :	More than 89 dB
Dynamic Range :	More than 89 dB
Total Harmonic Distortion :	Less than 0.007% (SP), less than 0.07% (LP) (1 kHz for recording and playback, full-scale)
Channel Separation :	More than 85 dB (1 kHz)
Wow and Flutter :	Unmeasurable (less than \pm 0.001%)

Analog Input/Output Connectors

IN :	RCA pin x 2
Normal Input Level :	-10 dBV (0.3 V), unbalanced (FS - 16 dB)
Input Impedance :	20 kohms
OUT :	RCA pin x 4
Normal Output Level :	-10 dBV (0.3 V), unbalanced (FS - 16 dB)
Maximum Output Level :	+6 dBV (2.0 V), unbalanced (10-kohm load)
Output impedance :	Less than 1 kohm
CASCADE OUTPUT :	RCA pin x 2
Normal Output Level :	-10 dBV (0.3 V), unbalanced (FS - 16 dB)
Maximum Output Level :	+6 dBV (2.0 V), unbalanced (10-kohm load)
Output impedance :	Less than 1 kohm
PHONES:	6.3 mm dia. phone jack x 1
Maximum Output Level :	50 mW + 50 mW (32-ohm load)

Digital Input /Output Connectors

INPUTS :	RCA pin x 2
Format :	IEC958 TYPE I (AES/EBU), IEC958 TYPE II (SPDIF), automatic selection
Input Impedance :	75 ohms
OUTPUTS: RCA pin x 2	
Format :	IEC958 TYPE I (AES/EBU), IEC958 TYPE II (SPDIF), selected with menu
Output Level :	More than 0.5 Vp-p
Output Impedance :	75 ohms
CASCADE OUTPUT :	RCA pin x 1
Format :	Conforming to DIGITAL OUTPUTS
Output Level :	More than 0.5 Vp-p
Output Impedance :	75 ohms

Control Input/Output Connectors

INPUT :	3.5 mm dia. mini-jack
Input Level :	TTL level
OUTPUT :	3.5 mm dia. mini-jack
Output level :	TTL level

Remote Control Input Connector :

3.5 mm dia. mini-jack

Power Supply :

U.S.A./Canada :	120 V AC, 60 Hz
U.K./AUSTRALIA :	240 V AC, 50 Hz
EUROPE :	230 V AC, 50 Hz

Power Consumption :

27 watts

Dimensions (WxHxD) :

482 x 150.5 x 353 mm

(19" x 6-3/32" x 13-7/8")

Weight :

7.2 kg (15.9 lbs.)

- In these specifications, 0 dBV is referenced to 1.0 Vrms. However, actual voltage levels are also given in parentheses (0.316 V for -10 dBV rounded off to 0.3 V)
- Changes in specifications and features may be made without notice or obligation.

DA-302 External Dimensions

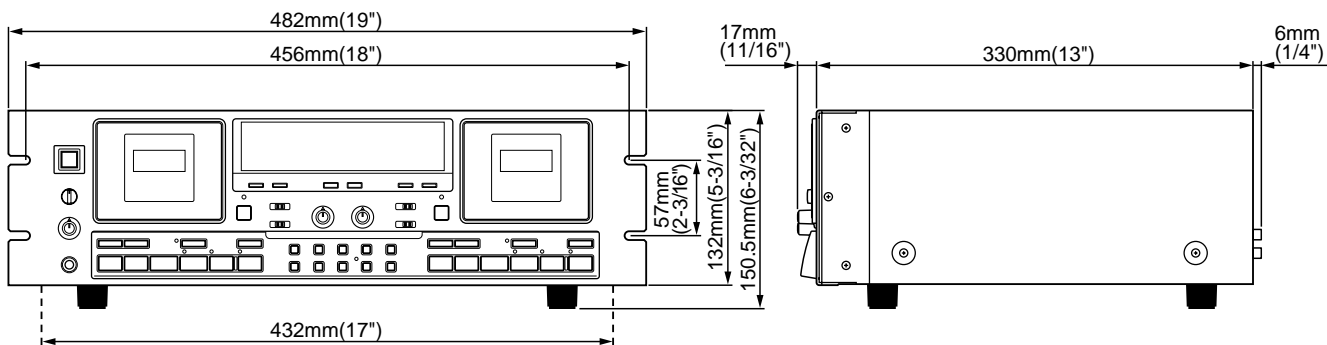

DA-302 External Dimensions

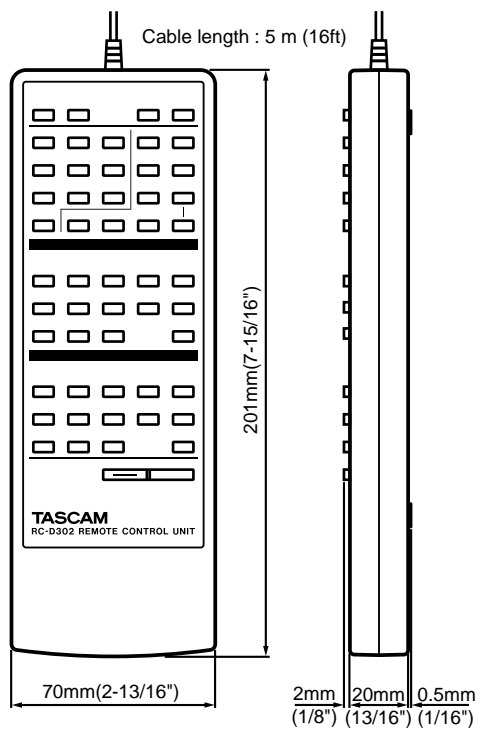

Section 12 : Warning Indications and Error Messages

12-1. Warning indications during operation

Indication	Content
NoPGM	Program dubbing is attempted when no programs have been programmed.
RecProh	Recording is attempted when the cassette's write protect switch is open (Write Protection On).
Proh	Recording is attempted on Deck 2 with the INPUT switch set to ANALOG and the COMMON MODE switch set to OFF.
ComSwOn	Recording is attempted on Deck 2 with the COMMON MODE switch set to 1 → 2.
Not Ready	Operation keys on either Deck 1 or Deck 2 cannot be used when the COMMON MODE switch is set to 1&2. e.g.) The tape in Deck 1 stops at the beginning and Deck 1's PLAY key is pressed while the tape in Deck 2 is being rewound.
TapeCut	The tape is broken.

12-2. Error messages

Indica-tion	Content	Remedies
Err 01	Loading error	Turn the power off and on again. If the error message remains after repeating this procedure a few times, contact your nearest TASCAM service dealer.
Err 04	Capstan error	
Err 02	Drum error	
	Condensation on drum	Leave the DA-302's power ON for between 1 and 2 hours.

- If an error message (Err xx) not listed above is shown, turn the power off and on again. If the error message remains after repeating this procedure a few times, contact your nearest TASCAM service dealer.

Section 13 : Optional Accessories

LA-D302 Balanced Amplifier Kit

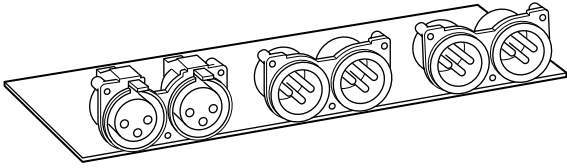

Specifications

Analog input connector (XLR-3-31 type x 2) (#2 hot)

Reference input level:

+4 dBu, balanced (FS -16 dB)

Input impedance: More than 10 kohms

Analog output connector (XLR-3-32 type x 4) (#2 hot)

Reference output level:

+4 dBu, balanced (FS -16 dB)

Maximum output level: +20 dBu, balanced

Output impedance:

75 ohms (load of more than 600 ohms)

WR-7000 Sync Cable

When using more than one DA-302, connect this cable to the EXT CONTROL connectors. (☞ p.26)

TASCAM

TEAC Professional Division

DA-302

TEAC CORPORATION

3-7-3, Nakacho, Musashino-shi, Tokyo 180, Japan Phone: (0422) 52-5082

TEAC AMERICA, INC.

7733 Telegraph Road, Montebello, California 90640 Phone: (213) 726-0303

TEAC CANADA LTD.

5939 Wallace Street, Mississauga, Ontario L4Z 1Z8, Canada Phone: 905-890-8008 Facsimile: 905-890-9888

TEAC MEXICO, S.A. De C.V.

Privada De Corina, No.18, Colonia Del Carmen Coyoacan, Mexico DF 04100 Phone: 5-658-1943

TEAC UK LIMITED

5 Marlin House, Marlin Meadow, The Croxley Centre, Watford, Herts. WD1 8YA, U.K. Phone: 01923-819699

TEAC DEUTSCHLAND GmbH

Bahnstrasse 12, 65205 Wiesbaden-Erbenheim, Germany Phone: 0611-71580

TEAC FRANCE S. A.

17 Rue Alexis-de-Tocqueville, CE 005 92182 Antony Cedex, France Phone: (01) 42.37.01.02

TEAC BELGIUM NV/SA

P.A. TEAC Nederland BV, Perkinsbaan 11a, 3439 ND Nieuwegein, Netherlands Phone: 0031-30-6048115

TEAC NEDERLAND BV

Perkinsbaan 11a, 3439 ND Nieuwegein, Netherlands Phone: 030-6030229

TEAC AUSTRALIA PTY., LTD.
A.C.N. 005 408 462

106 Bay Street, Port Melbourne, Victoria 3207, Australia Phone: (03) 9644-2442

TEAC ITALIANA S.p.A.

Via C. Cantù 5, 20092 Cinisello Balsamo, Milano, Italy Phone: 02-66010500
