

# TASCAM

TEAC Professional Division

# MA-8

## 8-Channel Microphone Preamplifier

## Pré-ampli MICRO 8 canaux

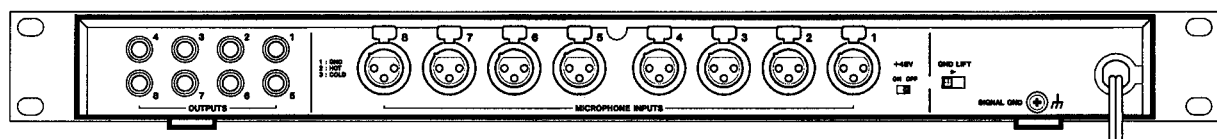
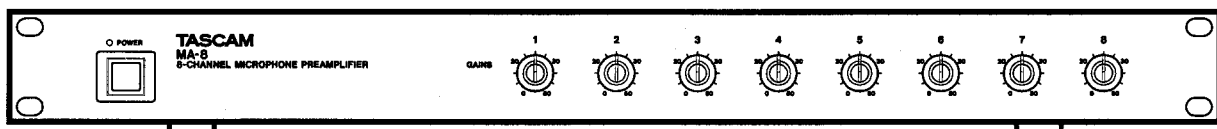

**OWNER'S MANUAL  
MANUEL DU PROPRIETAIRE**

D00127500A

# Important Safety Precautions



**CAUTION: TO REDUCE THE RISK OF ELECTRIC SHOCK, DO NOT REMOVE COVER (OR BACK). NO USER-SERVICEABLE PARTS INSIDE. REFER SERVICING TO QUALIFIED SERVICE PERSONNEL.**



The lightning flash with arrowhead symbol, within equilateral triangle, is intended to alert the user to the presence of uninsulated "dangerous voltage" within the product's enclosure that may be of sufficient magnitude to constitute a risk of electric shock to person.



The exclamation point within an equilateral triangle is intended to alert the user to the presence of important operating and maintenance (servicing) instructions in the literature accompanying the appliance.

This appliance has a serial number located on the rear panel. Please record the model number and serial number and retain them for your records.  
Model number \_\_\_\_\_  
Serial number \_\_\_\_\_

**WARNING: TO PREVENT FIRE OR SHOCK HAZARD, DO NOT EXPOSE THIS APPLIANCE TO RAIN OR MOISTURE.**

## IMPORTANT (for U.K. Customers)

**DO NOT cut off the mains plug from this equipment.** If the plug fitted is not suitable for the power points in your home or the cable is too short to reach a power point, then obtain an appropriate safety approved extension lead or consult your dealer.

If nonetheless the mains plug is cut off, remove the fuse and dispose of the plug immediately, to avoid a possible shock hazard by inadvertent connection to the mains supply.

If this product is not provided with a mains plug, or one has to be fitted, then follow the instructions given below:

**IMPORTANT. DO NOT** make any connection to the larger terminal which is marked with the letter E or by the safety earth symbol  $\perp$  or coloured GREEN or GREEN-and-YELLOW.

The wires in the mains lead on this product are coloured in accordance with the following code:

**BLUE:** NEUTRAL  
**BROWN:** LIVE

As these colours may not correspond with the coloured markings identifying the terminals in your plug proceed as follows:

The wire which is coloured BLUE must be connected to the terminal which is marked with the letter N or coloured BLACK.

The wire which is coloured BROWN must be connected to the terminal which is marked with the letter L or coloured RED.

When replacing the fuse only a correctly rated approved type should be used and be sure to re-fit the fuse cover.

IF IN DOUBT — CONSULT A COMPETENT ELECTRICIAN.

## For the consumers in Europe

### WARNING

This is a Class A product. In a domestic environment, this product may cause radio interference in which case the user may be required to take adequate measures.

## Pour les utilisateurs en Europe

### AVERTISSEMENT

Il s'agit d'un produit de Classe A. Dans un environnement domestique, cet appareil peut provoquer des interférences radio, dans ce cas l'utilisateur peut être amené à prendre des mesures appropriées.

## Für Kunden in Europa

### Warnung

Dies ist eine Einrichtung, welche die Funk-Entstörung nach Klasse A besitzt. Diese Einrichtung kann im Wohnbereich Funkstörungen verursachen; in diesem Fall kann vom Betreiber verlangt werden, angemessene Maßnahmen durchzuführen und dafür aufzukommen.

## For CANADA

### AC POWER CORD CONNECTION

#### CAUTION:

TO PREVENT ELECTRIC SHOCK, MATCH WIDE BLADE OF PLUG TO WIDE SLOT, FULLY INSERT.

### CORDE DE CONNEXION CA

#### ATTENTION:

POUR ÉVITER LES CHOCs ÉLECTRIQUES, INTRODUIRE LA LAME LA PLUS LARGE DE LA FICHE DANS LA BORNE CORRESPONDANTE DE LA PRISE ET POUSSER JUSQU' AU FOND.

**MICROPHONE CABLES AND MICROPHONES CONNECTION:** TO PREVENT HAZARD OR DAMAGE, ENSURE THAT ONLY MICROPHONE CABLES AND MICROPHONES DESIGNED TO THE IEC 268-15A STANDARD ARE CONNECTED.

**CONNEXIONS DES MICROPHONES ET DE LEURS CABLES:** POUR ÉVITER TOUT ENDOMMAGEMENT, S'ASSURER DE BRANCHER UNIQUEMENT DES MICROPHONES ET DES CABLES DE MICROPHONES CONÇUS SELON LA NORME IEC 268-15A.

# SAFETY INSTRUCTIONS

## CAUTION:

- Read all of these Instructions.
- Save these Instructions for later use.
- Follow all Warnings and Instructions marked on the audio equipment.

- 1) **Read instructions** — All the safety and operating instructions should be read before the product is operated.
- 2) **Retain instructions** — The safety and operating instructions should be retained for future reference.
- 3) **Heed Warnings** — All warnings on the product and in the operating instructions should be adhered to.
- 4) **Follow instructions** — All operating and use instructions should be followed.
- 5) **Cleaning** — Unplug this product from the wall outlet before cleaning. Do not use liquid cleaners or aerosol cleaners. Use a damp cloth for cleaning.
- 6) **Attachments** — Do not use attachments not recommended by the product manufacturer as they may cause hazards.
- 7) **Water and Moisture** — Do not use this product near water — for example, near a bath tub, wash bowl, kitchen sink, or laundry tub; in a wet basement; or near a swimming pool; and the like.
- 8) **Accessories** — Do not place this product on an unstable cart, stand, tripod, bracket, or table. The product may fall, causing serious injury to a child or adult, and serious damage to the product. Use only with a cart, stand, tripod, bracket, or table recommended by the manufacturer, or sold with the product. Any mounting of the product should follow the manufacturer's instructions, and should use a mounting accessory recommended by the manufacturer.
- 9) A product and cart combination should be moved with care. Quick stops, excessive force, and uneven surfaces may cause the product and cart combination to overturn.



- 10) **Ventilation** — Slots and openings in the cabinet are provided for ventilation and to ensure reliable operation of the product and to protect it from overheating, and these openings must not be blocked or covered. The openings should never be blocked by placing the product on a bed, sofa, rug, or other similar surface. This product should not be placed in a built-in installation such as a bookcase or rack unless proper ventilation is provided or the manufacturer's instructions have been adhered to.
- 11) **Power Sources** — This product should be operated only from the type of power source indicated on the marking label. If you are not sure of the type of power supply to your home, consult your product dealer or local power company. For products intended to operate from battery power, or other sources, refer to the operating instructions.
- 12) **Grounding or Polarization** — This product may be equipped with a polarized alternating-current line plug (a plug having one blade wider than the other). This plug will fit into the power outlet only one way. This is a safety feature. If you are unable to insert the plug fully into the outlet, try reversing the plug. If the plug should still fail to fit, contact your electrician to replace your obsolete outlet. Do not defeat the safety purpose of the polarized plug.
- 13) **Power-Cord Protection** — Power-supply cords should be routed so that they are not likely to be walked on or pinched by items placed upon or against them, paying particular attention to cords at plugs, convenience receptacles, and the point where they exit from the product.
- 14) **Outdoor Antenna Grounding** — If an outside antenna or cable system is connected to the product, be sure the antenna or cable system is grounded so as to provide some protection against voltage surges and built-up static charges. Article 810 of the National Electrical Code, ANSI/NFPA 70, provides information with regard to proper grounding of the mast and supporting structure, grounding of the lead-in wire to an antenna discharge unit, size of grounding conductors, location of antenna-discharge unit, connection to grounding electrodes, and requirements for the grounding electrode.

## "Note to CATV system installer:

This reminder is provided to call the CATV system installer's attention to Section 820-40 of the NEC which provides guidelines for proper grounding and, in particular, specifies that the cable ground shall be connected to the grounding system of the building, as close to the point of cable entry as practical.

Example of Antenna Grounding as per National Electrical Code, ANSI/NFPA 70

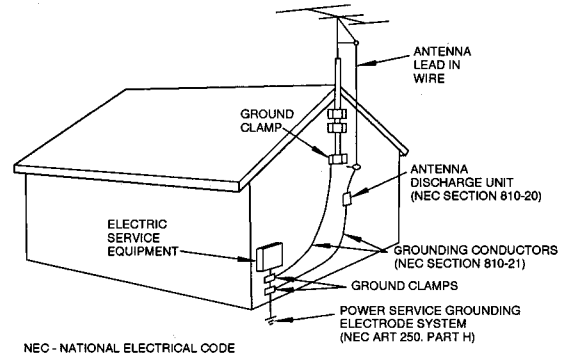

- 15) **Lightning** — For added protection for this product during a lightning storm, or when it is left unattended and unused for long periods of time, unplug it from the wall outlet and disconnect the antenna or cable system. This will prevent damage to the product due to lightning and power-line surges.
- 16) **Power Lines** — An outside antenna system should not be located in the vicinity of overhead power lines or other electric light or power circuits, or where it can fall into such power lines or circuits. When installing an outside antenna system, extreme care should be taken to keep from touching such power lines or circuits as contact with them might be fatal.
- 17) **Overloading** — Do not overload wall outlets, extension cords, or integral convenience receptacles as this can result in risk of fire or electric shock.
- 18) **Object and Liquid Entry** — Never push objects of any kind into this product through openings as they may touch dangerous voltage points or short-out parts that could result in a fire or electric shock. Never spill liquid of any kind on the product.
- 19) **Servicing** — Do not attempt to service this product yourself as opening or removing covers may expose you to dangerous voltage or other hazards. Refer all servicing to qualified service personnel.
- 20) **Damage Requiring Service** — Unplug this product from the wall outlet and refer servicing to qualified service personnel under the following conditions:
  - a) when the power-supply cord or plug is damaged.
  - b) if liquid has been spilled, or objects have fallen into the product.
  - c) if the product has been exposed to rain or water.
  - d) if the product does not operate normally by following the operating instructions. Adjust only those controls that are covered by the operating instructions as an improper adjustment of other controls may result in damage and will often require extensive work by a qualified technician to restore the product to its normal operation.
  - e) if the product has been dropped or damaged in any way.
  - f) when the product exhibits a distinct change in performance — this indicates a need for service.
- 21) **Replacement Parts** — When replacement parts are required, be sure the service technician has used replacement parts specified by the manufacturer or have the same characteristics as the original part. Unauthorized substitutions may result in fire, electric shock, or other hazards.
- 22) **Safety Check** — Upon completion of any service or repairs to this product, ask the service technician to perform safety checks to determine that the product is in proper operating condition.
- 23) **Wall or Ceiling Mounting** — The product should be mounted to a wall or ceiling only as recommended by the manufacturer.
- 24) **Heat** — The product should be situated away from heat sources such as radiators, heat registers, stoves, or other products (including amplifiers) that produce heat.

# CONTROLS AND CONNECTORS / EQUIPEMENTS ET FONCTIONS

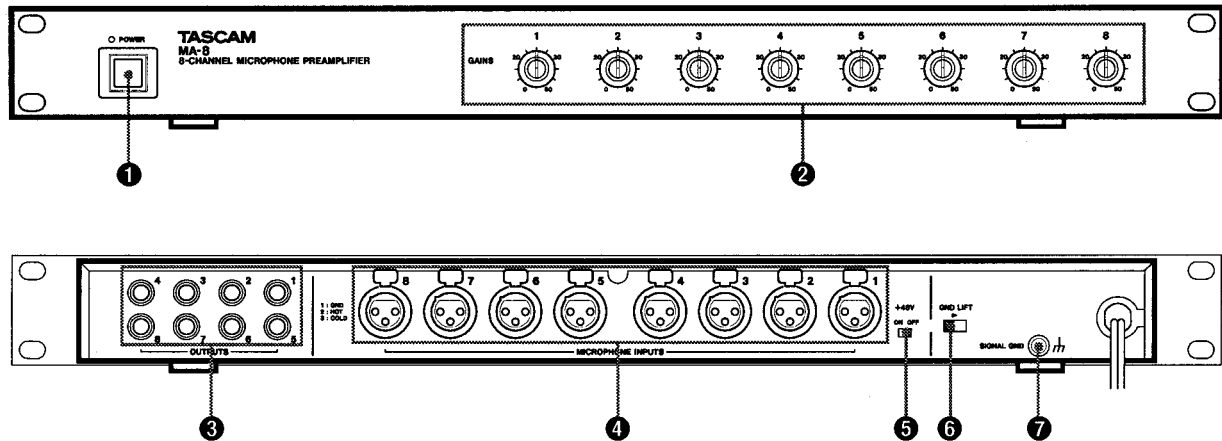

## Front Panel

- ① **POWER switch** : Turns the unit on or off. The associated LED lights upon powering up.
- ② **GAIN controls** : Used to adjust the amplifier's gain over a wide range of from -57 dBm to -2 dBm.

## Rear Panel

- ③ **OUTPUTS** : These 1/4" jacks (unbalanced) are for connection to the line inputs of a mixer or others.
- ④ **MICROPHONE INPUTS** : These XLR-type sockets (balanced) are for connection of mics.
- ⑤ **+48V switch** : Pressing this switch sends +48 VDC to pins 2 (hot) and 3 (cold) of the eight XLR-type connectors. Check the owner's manual for the microphones to make sure that this method is correct before you apply power.
  - The phantom power is applied to all the eight MICROPHONE INPUTS at one time. But, balanced dynamic microphones requiring no external power can be used at the same time as phantom-powered condenser-type microphones.
  - DO NOT use the MA-8's phantom power when you use microphones requiring external power at the same time as unbalanced microphones requiring no external power.
- ⑥ **GND LIFT switch** : When using the unit mounted together with others in a metal rack, hum or low-frequency noise is eventually generated because of a ground loop created through the enclosure of them. This switch is used to minimize such unwanted sounds.
- ⑦ **GND terminal** : This is a ground point connected to the MA-8 chassis.

## Panneau avant

- ① **Interrupteur POWER** : Mise sous/hors tension de l'appareil. Le témoin s'allume pour indiquer que l'appareil est sous tension.
- ② **Potentionmètres GAIN** : Sert à régler le gain du préampli de -57 dBm à -2 dBm.

## Panneau arrière

- ③ **OUTPUTS** : La sortie par ces jacks quart de pouce en asymétrie sera branchée sur les entrées ligne d'un mixeur ou d'autres.
- ④ **MICROPHONE INPUTS** : Des micros seront branchés sur ces prises de type XLR en symétrie.
- ⑤ **Interrupteur +48V** : A la pression sur cet interrupteur, les broches 2 (niveau haut) et 3 (niveau bas) de chacune des 8 prises d'entrée micro sont alimentées en +48 V c.c.
  - L'alimentation fantôme est appliquée à toutes les 8 entrées micro sans distinction. Il vous est quand même loisible de vous servir des micros dynamiques en symétrie qui n'ont pas besoin d'alimentation externe, en même temps que des micros à condensateur qui ont besoin d'alimentation externe.
  - Ne pas mettre en service l'alimentation fantôme de cet ampli quand vous y branchez des micros qui fonctionnent grâce à une alimentation externe en même temps que des micros asymétriques qui n'ont pas besoin d'alimentation externe.
- ⑥ **Interrupteur GND LIFT** : Prévu pour la minimisation des bruits ayant pour cause une boucle de masse qui peut se former, quand le MA-08 est monté dans un rack métal conjointement avec d'autres appareil, à travers leur tôle.
- ⑦ **Borne GND** : C'est un point de masse châssis du MA-8.

# INTRODUCTION

The TASCAM MA-8 includes the following features :

- The inputs are handled by XLR-type connectors, and the outputs by 1/4" phone jacks.
- The outputs operate at the same level as the internal operating level of the TASCAM M-1600 mixers, that is, at -2 dBu.
- Phantom power is implemented.
- A ground lift switch is mounted.

## Table of Contents

Controls and Connectors .....	4
Front panel .....	4
Rear panel .....	4
Introduction .....	5
Unpacking .....	5
Installation site .....	5
Care of the MA-8 .....	5
Mounting in a 19" rack .....	5
Dimensions.....	5
Specifications .....	6
Block/Level Diagram .....	6

## Unpacking

The box contains the following :

1. MA-8 8-channel Microphone Preamplifier ..... x1
2. Accessories
  - (1) Rack mount screw kit ..... x1
  - (2) Owner's manual ..... x1
3. Warranty card ..... x1

## Installation Site

- Nominal temperature should be 5 to 35 degrees Centigrade (41 to 95 degrees Fahrenheit).

## Care of the MA-8

- Be careful not to drop the unit or don't subject it to severe impact.
- When cleaning the exterior of the unit, use a soft cloth. If necessary, moisten a soft cloth with mild solution of detergent and water. Do not use any type of solvents such as alcohol or benzine.

## Mounting in a 19" rack / Montage dans un rack 19"

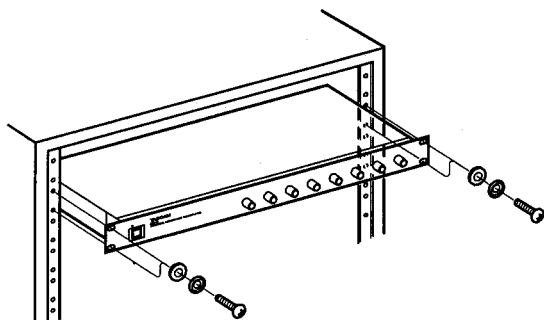

Les caractéristiques du pré-ampli micro 8 canaux de TASCAM comprennent :

- Entrées par prises type-XLR et sorties par jack quart de pouce 2 contacts.
- Les sorties opèrent au même niveau que celui de référence interne des mixeurs série M-1600 de TASCAM, soit à -2 dBu.
- Alimentation fantôme
- Commutateur d'arrêt des contacts de masse

## Sommaire

Equipements et fonctions .....	4
Panneau avant .....	4
Panneau arrière .....	4
Introduction .....	5
Contenus du carton.....	5
Endroit d'installation .....	5
Soin du M-8 .....	5
Montage dans un rack 19".....	5
Dimensions.....	5
Fiche technique.....	6
Synoptique/diagramme de niveaux .....	6

## Contenus du carton

Le carton contient :

1. Pré-ampli micro 8 canaux MA-8 ..... 1
2. Accessoires
  - (1) Jeu de vis de montage rack..... 1
  - (2) Mode d'emploi..... 1
3. Carte de garantie ..... 1

## Endroit d'installation

- Eviter les températures supérieures à 35 degrés ou inférieurs à 5 degrés C.

## Soin du MA-8

- Faire attention de ne pas laisser tomber l'appareil ni de lui donner tout autre choc brutal.
- Nettoyer l'extérieur de l'appareil avec un chiffon doux légèrement imprégné d'une solution douce de détergent et d'eau. N'utiliser aucun type de tampon abrasif, pour-dre de récurage ou diluants tels qu'alcool ou benzine.

## Dimensions

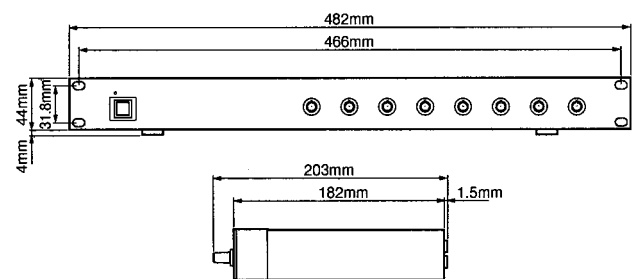

# SPECIFICATIONS / FICHE TECHNIQUE

## ■Electronics

### MICROPHONE INPUTS (Balanced, XLR-type x8)

Input impedance : 2.2 kohms  
Nominal input level : -57 dBm to -2 dBm  
Trim range : 55 dB

### OUTPUTS (Unbalanced, 1/4" phone jack x8)

Output impedance : 100 ohms  
Load impedance : 1 kohms  
Nominal output level : -2 dBu  
Maximum output level : 22 dBu

### Power Requirements :

USA/CANADA : 120 V AC, 60 Hz  
U.K./EUROPE : 230 V AC, 50 Hz

Power Consumption : 9 Watts

Weight : 2.7 kg (5-15/16 lbs)

Dimensions (W x H x D) : 482 x 48 x 203 mm (19" x 1-7/8" x 8")

### ■Typical Performance

Equivalent Input Noise (DIN AUDIO, GAIN MAX, terminated in 150-ohm load) : -128 dBm

Noise Level (IHF-A, terminated in 150-ohm load)

GAIN Min.: Less than -100 dBV (7.8  $\mu$ V)  
GAIN Max.: Less than -77 dBV (110  $\mu$ V)

CMRR (Common Mode Rejection Ratio) :

Better than 75 dB (at 1 kHz)

Total Harmonic Distortion : Less than 0.013% (at 1 kHz)

Frequency Response : 20 Hz to 30 kHz +0/-1.5 dB

Crosstalk : Better than 75 dB (at 1 kHz, terminated in 150-ohm load)

- In these specifications, 0 dBV is referenced to 1.0 Vrms, and 0 dBm (bal.)/ 0 dBu (unbal.) is referenced to 0.775 V rms. Actual voltage for -100 dBV (7.75  $\mu$ V) is rounded up to 7.8  $\mu$ V.

- Changes in specifications and features may be made without notice or obligation.

## ■Electroniques

### MICROPHONE INPUTS (en symétrie, type XLR x8)

Impédance d'entrée : 2,2 kohms  
Niveau nominal d'entrée : -57 dBm à -2 dBm  
Réglage Trim : 55 dB

### OUTPUTS (en asymétrie, 1/4" téléphone x8)

Impédance de sortie : 100 ohms  
Impédance de charge : 1 kohms  
Niveau nominal de sortie : -2 dBu  
Niveau maximum de sortie : 22 dBu

### Alimentation :

Etats-Unis/Canada : 120 V CA, 60 Hz  
Royaume-Uni/Europe : 230 V CA, 50 Hz

Consommation : 9 Watts

Poids : 2,7 kg

Dimensions (L x H x P) : 482 x 48 x 203 mm (19" x 1-7/8" x 8")

### ■Performance typique

Bruit d'entrée équivalent (pondéré DIN AUDIO, GAIN au maxi., sous une charge de 150 ohms) : -128 dBm

Niveau de bruit (pondéré IHF-A, sous une charge de 150 ohms)

GAIN au min. : Inférieur à -100 dBV (7,8  $\mu$ V)  
GAIN au maxi. : Inférieur à -77 dBV (110  $\mu$ V)

CMRR (Common Mode Rejection Ratio) :

Supérieur à 75 dB (à 1 kHz)

Distorsion harmonique totale : Inférieure à 0,013% (à 1 kHz)

Réponse des fréquences : 20 Hz à 30 kHz +0/-1,5 dB

Diaphonie : Supérieure à 75 dB (à 1 kHz, sous une charge de 150 ohms)

- Dans la fiche technique, 0 dBV correspond à 1,0 Vrms, et 0 dBm (symétrie)/ 0 dBu (asymétrie) correspond à 0,775 Vrms. La tension actuelle pour -100 dBV soit 7,75  $\mu$ V est arrondie en 7,8  $\mu$ V.

- Les spécifications et l'aspect sont susceptibles d'être modifiés sans avis préalable.

## Block/Level Diagram / Synoptique/diagramme de niveaux

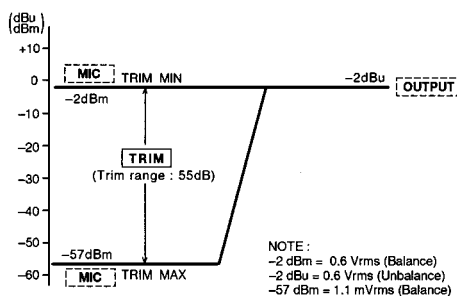
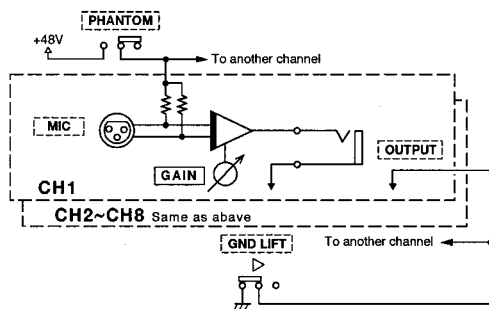

## TEAC CORPORATION

3-7-3, Nakacho, Musashino-shi, Tokyo 180, Japan Phone: (0422) 52-5081

TEAC AMERICA, INC.

7733 Telegraph Road, Montebello, California 90640 Phone: (213) 726-0303

TEAC CANADA LTD.

340 Brunel Road, Mississauga, Ontario L4Z 2C2, Canada Phone: 905-890-8008

TEAC UK LIMITED

5 Marlin House, Marlin Meadow, The Croxley Centre, Watford, Herts. WD1 8YA, U.K. Phone: 01923-819699

TEAC DEUTSCHLAND GmbH

Bahnstrasse 12, 65205 Wiesbaden-Erbenheim, Germany Phone: 0611-71580

TEAC FRANCE S.A.

17, Rue Alexis-de-Tocqueville, CE 005 92182 Antony Cedex, France Phone: (1) 42.37.01.02

TEAC NEDERLAND BV

Perkinsbaan 11, 3439 ND Nieuwegein, Nederland Phone: 03-402-30229

TEAC AUSTRALIA PTY., LTD.  
A.C.N. 005 408 462

106 Bay Street, Port Melbourne, Victoria 3207, Australia Phone: (03) 9644-2442

TEAC ITALIANA S.p.A.

Via C. Cantù 5, 20092 Cinisello Balsamo, Milano, Italy Phone: 02-66010500