

# TASCAM

TEAC Professional Division

D00444800A

# MA-AD8

Digital Mic Amplifier

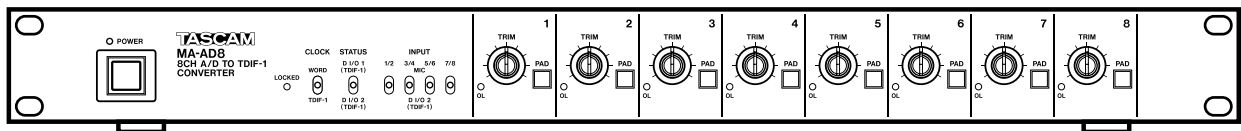

## OWNER'S MANUAL



**CAUTION**  
RISK OF ELECTRIC SHOCK  
DO NOT OPEN



**CAUTION:** TO REDUCE THE RISK OF ELECTRIC SHOCK, DO NOT REMOVE COVER (OR BACK). NO USER-SERVICEABLE PARTS INSIDE. REFER SERVICING TO QUALIFIED SERVICE PERSONNEL.



The lightning flash with arrowhead symbol, within an equilateral triangle, is intended to alert the user to the presence of uninsulated "dangerous voltage" within the product's enclosure that may be of sufficient magnitude to constitute a risk of electric shock to persons..



The exclamation point within an equilateral triangle is intended to alert the user to the presence of important operating and maintenance (servicing) instructions in the literature accompanying the appliance.

This appliance has a serial number located on the rear panel. Please record the model number and serial number and retain them for your records.

Model number \_\_\_\_\_  
Serial number \_\_\_\_\_

**WARNING: TO PREVENT FIRE OR SHOCK HAZARD, DO NOT EXPOSE THIS APPLIANCE TO RAIN OR MOISTURE.**

# Important Safety Precautions

## IMPORTANT (for U.K. Customers)

### **DO NOT cut off the mains plug from this equipment.**

If the plug fitted is not suitable for the power points in your home or the cable is too short to reach a power point, then obtain an appropriate safety approved extension lead or consult your dealer.

If nonetheless the mains plug is cut off, remove the fuse and dispose of the plug immediately, to avoid a possible shock hazard by inadvertent connection to the mains supply.

If this product is not provided with a mains plug, or one has to be fitted, then follow the instructions given below:

**IMPORTANT:** The wires in this mains lead are coloured in accordance with the following code:

<b>GREEN-AND-YELLOW</b>	: EARTH
<b>BLUE</b>	: NEUTRAL
<b>BROWN</b>	: LIVE

**WARNING:** This apparatus must be earthed.

As the colours of the wires in the mains lead of this apparatus may not correspond with the coloured markings identifying the terminals in your plug proceed as follows:

The wire which is coloured GREEN-and-YELLOW must be connected to the terminal in the plug which is marked by the letter E or by the safety earth symbol  $\perp$  or coloured GREEN or GREEN-and-YELLOW.

The wire which is coloured BLUE must be connected to the terminal which is marked with the letter N or coloured BLACK.

The wire which is coloured BROWN must be connected to the terminal which is marked with the letter L or coloured RED.

When replacing the fuse only a correctly rated approved type should be used and be sure to re-fit the fuse cover.

IF IN DOUBT — CONSULT A COMPETENT ELECTRICIAN.

For U.S.A

### TO THE USER

This equipment has been tested and found to comply with the limits for a Class A digital device, pursuant to Part 15 of the FCC Rules. These limits are designed to provide reasonable protection against harmful interference when the equipment is operated in a commercial environment. This equipment generates, uses, and can radiate radio frequency energy and, if not installed and used in accordance with the instruction manual, may cause harmful interference to radio communications.

Operation of this equipment in a residential area is likely to cause harmful interference in which case the user will be required to correct the interference at his own expense.

### CAUTION

Changes or modifications to this equipment not expressly approved by TEAC CORPORATION for compliance could void the user's authority to operate this equipment.

### For the consumers in Europe

#### WARNING

This is a Class A product. In a domestic environment, this product may cause radio interference in which case the user may be required to take adequate measures.

### Pour les utilisateurs en Europe

#### AVERTISSEMENT

Il s'agit d'un produit de Classe A. Dans un environnement domestique, cet appareil peut provoquer des interférences radio, dans ce cas l'utilisateur peut être amené à prendre des mesures appropriées.

### Für Kunden in Europa

#### Warnung

Dies ist eine Einrichtung, welche die Funk-Entstörung nach Klasse A besitzt. Diese Einrichtung kann im Wohnbereich Funkstörungen verursachen ; in diesem Fall kann vom Betreiber verlangt werden, angemessene Maßnahmen durchzuführen und dafür aufzukommen.

# IMPORTANT SAFETY INSTRUCTIONS

## CAUTION:

- Read all of these Instructions.
- Save these Instructions for later use.
- Follow all Warnings and Instructions marked on the audio equipment.

- 1) Read Instructions** — All the safety and operating instructions should be read before the product is operated.
- 2) Retain Instructions** — The safety and operating instructions should be retained for future reference.
- 3) Heed Warnings** — All warnings on the product and in the operating instructions should be adhered to.
- 4) Follow Instructions** — All operating and use instructions should be followed.
- 5) Cleaning** — Unplug this product from the wall outlet before cleaning. Do not use liquid cleaners or aerosol cleaners. Use a damp cloth for cleaning.
- 6) Attachments** — Do not use attachments not recommended by the product manufacturer as they may cause hazards.
- 7) Water and Moisture** — Do not use this product near water — for example, near a bath tub, wash bowl, kitchen sink, or laundry tub; in a wet basement; or near a swimming pool; and the like.
- 8) Accessories** — Do not place this product on an unstable cart, stand, tripod, bracket, or table. The product may fall, causing serious injury to a child or adult, and serious damage to the product. Use only with a cart, stand, tripod, bracket, or table recommended by the manufacturer, or sold with the product. Any mounting of the product should follow the manufacturer's instructions, and should use a mounting accessory recommended by the manufacturer.
- 9) A product and cart combination should be moved with care.** Quick stops, excessive force, and uneven surfaces may cause the product and cart combination to overturn.



- 10) Ventilation** — Slots and openings in the cabinet are provided for ventilation and to ensure reliable operation of the product and to protect it from overheating, and these openings must not be blocked or covered. The openings should never be blocked by placing the product on a bed, sofa, rug, or other similar surface. This product should not be placed in a built-in installation such as a bookcase or rack unless proper ventilation is provided or the manufacturer's instructions have been adhered to.
- 11) Power Sources** — This product should be operated only from the type of power source indicated on the marking label. If you are not sure of the type of power supply to your home, consult your product dealer or local power company. For products intended to operate from battery power, or other sources, refer to the operating instructions.
- 12) Grounding or Polarization** — This product may be equipped with a polarized alternating-current line plug (a plug having one blade wider than the other). This plug will fit into the power outlet only one way. This is a safety feature. If you are unable to insert the plug fully into the outlet, try reversing the plug. If the plug should still fail to fit, contact your electrician to replace your obsolete outlet. Do not defeat the safety purpose of the polarized plug.
- 13) Power-Cord Protection** — Power-supply cords should be routed so that they are not likely to be walked on or pinched by items placed upon or against them, paying particular attention to cords at plugs, convenience receptacles, and the point where they exit from the product.
- 14) Outdoor Antenna Grounding** — If an outside antenna or cable system is connected to the product, be sure the antenna or cable system is grounded so as to provide some protection against voltage surges and built-up static charges. Article 810 of the National Electrical Code, ANSI/NFPA 70, provides information with regard to proper grounding of the mast and supporting structure, grounding of the lead-in wire to an antenna discharge unit, size of grounding conductors, location of antenna-discharge unit, connection to grounding electrodes, and requirements for the grounding electrode.

## "Note to CATV system installer:

This reminder is provided to call the CATV system installer's attention to Section 820-40 of the NEC which provides guidelines for proper grounding and, in particular, specifies that the cable ground shall be connected to the grounding system of the building, as close to the point of cable entry as practical.

Example of Antenna Grounding as per National Electrical Code, ANSI/NFPA 70

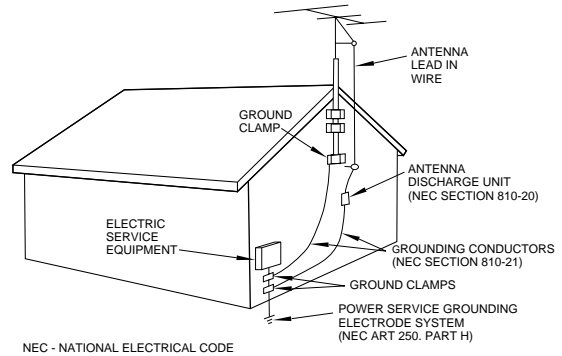

- 15) Lightning** — For added protection for this product during a lightning storm, or when it is left unattended and unused for long periods of time, unplug it from the wall outlet and disconnect the antenna or cable system. This will prevent damage to the product due to lightning and power-line surges.
- 16) Power Lines** — An outside antenna system should not be located in the vicinity of overhead power lines or other electric light or power circuits, or where it can fall into such power lines or circuits. When installing an outside antenna system, extreme care should be taken to keep from touching such power lines or circuits as contact with them might be fatal.
- 17) Overloading** — Do not overload wall outlets, extension cords, or integral convenience receptacles as this can result in risk of fire or electric shock.
- 18) Object and Liquid Entry** — Never push objects of any kind into this product through openings as they may touch dangerous voltage points or short-out parts that could result in a fire or electric shock. Never spill liquid of any kind on the product.
- 19) Servicing** — Do not attempt to service this product yourself as opening or removing covers may expose you to dangerous voltage or other hazards. Refer all servicing to qualified service personnel.
- 20) Damage Requiring Service** — Unplug this product from the wall outlet and refer servicing to qualified service personnel under the following conditions:
  - a) when the power-supply cord or plug is damaged.
  - b) if liquid has been spilled, or objects have fallen into the product.
  - c) if the product has been exposed to rain or water.
  - d) if the product does not operate normally by following the operating instructions. Adjust only those controls that are covered by the operating instructions as an improper adjustment of other controls may result in damage and will often require extensive work by a qualified technician to restore the product to its normal operation.
  - e) if the product has been dropped or damaged in any way.
  - f) when the product exhibits a distinct change in performance — this indicates a need for service.
- 21) Replacement Parts** — When replacement parts are required, be sure the service technician has used replacement parts specified by the manufacturer or have the same characteristics as the original part. Unauthorized substitutions may result in fire, electric shock, or other hazards.
- 22) Safety Check** — Upon completion of any service or repairs to this product, ask the service technician to perform safety checks to determine that the product is in proper operating condition.
- 23) Wall or Ceiling Mounting** — The product should be mounted to a wall or ceiling only as recommended by the manufacturer.
- 24) Heat** — The product should be situated away from heat sources such as radiators, heat registers, stoves, or other products (including amplifiers) that produce heat.

# MA-AD8 Digital Mic Amplifier

The TASCAM MA-AD8 Digital Mic Amplifier provides eight channels of analog-to-digital conversion at 20-bit resolution into TDIF-1 digital audio format, suitable for connection to a suitably-equipped digital mixing console or to a DTRS recorder, etc. The unit is housed in a convenient and compact 1U rack-mount format.

Two TDIF-1 connectors are provided, allowing the simultaneous connection of a digital mixing console and digital recorder. Each connector carries eight channels of TDIF-1 format audio for input or output.

The source of the output to one of the TDIF-1 connectors may be selected, in pairs of channels, as either the analog inputs or the other TDIF-1 connector. This allows a great deal of flexibility in recording situations, without the need for digital patching.

Together with the analog-to-digital convertors, the MA-AD8 also provides high-quality microphone amplifiers for ultimate sonic quality when making digital recordings.

Selectively switchable phantom power is available on the balanced microphone inputs, allowing a range of different microphones to be connected.

A  $-22$  dB **PAD** and a flexible **TRIM** control on each channel allow these inputs to be used with line-level signal sources as well as with microphone-level sources.

The word clock source for the MA-AD8 may be either of the two TDIF-1 connections, or an external independent word clock.

Front panel switches and indicators provide instant control and status indication of the MA-AD8's operation at all times.

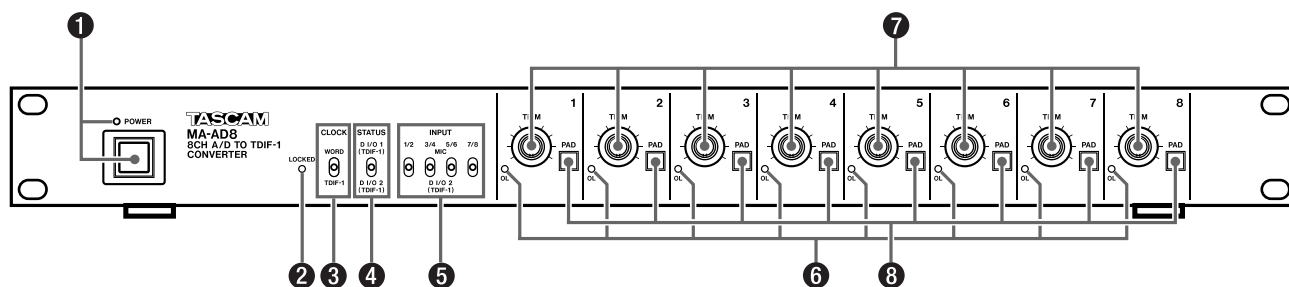

## 1.1 Front panel

### 1 POWER switch and indicator

Push the **POWER** switch once to turn on power, and again to turn it off. The **POWER** indicator lights when power is supplied to the MA-AD8.

### 2 LOCKED indicator

This indicator lights when a valid clock signal is received from the selected clock source (see **CLOCK SWITCH** 3).

If no clock signal is received at the selected source, or if the clock signal is outside the limits of tolerance (44.1 kHz or 48 kHz,  $\pm 6\%$ ) this indicator will not light, and the unit will not function.

### 3 CLOCK switch

This switch allows the selection of the clock source that will be used to synchronize the digital audio output of the MA-AD8. The two settings are **WORD** (the **WORD IN** 10 connector will be used as the clock source) and **TDIF-1** (either **DIGITAL I/O1 (FROM MIC INPUTS)** 11 or **DIGITAL I/O2 (AUX)** 12 will be used, depending on the setting of the **STATUS** switch 4).

## WARNING

*There should never be more than one word clock signal in a digital audio system. If there are not, at worst, damage may occur to speakers, amplifiers, etc. as a result of high-frequency noise generated by word clock incompatibilities.*

### 4 STATUS switch

If the **CLOCK** switch 3 is set to **TDIF-1**, this switch is used to select which of the TDIF-1 connectors (**DIGITAL I/O1 (FROM MIC INPUTS)** 11 or **DIGITAL I/O2 (AUX)** 12) will be used to provide the clock source.

In addition to the clock source, the selected TDIF-1 connector provides the MA-AD8 with FS Code, emphasis, and other status information, whether or not the **CLOCK** switch is set to **TDIF-1**.

### 5 INPUT switches

These four switches determine the source of the signal passed to the **DIGITAL I/O1 (FROM MIC INPUTS)** 11. These switches work in pairs, 1/2, 3/4, etc.

When one of these switches is in the up position, the signals passed to the **DIGITAL I/O1** connector for the corresponding channels will be the appropriate mic inputs (the XLR connectors on the rear panel).

When one of these switches is in the down position, the signal passed to the **DIGITAL I/O1** connector for the corresponding channels will be the two appropriate channels of the digital audio received at **DIGITAL I/O2 (AUX)** ⑫.

This allows digital repatching of multitrack recorders to the mixer on overdubbing and mixdown etc. without the need to disconnect and re-connect cables.

## NOTES

*When these switches are operated, an audible click may occur. To avoid damage to monitor speakers, etc., turn down the level of all monitoring equipment before operating these switches.*

*The digital signals received at the **DIGITAL I/O1** connector are always output to*

*the **DIGITAL I/O2** connector, and cannot be rerouted.*

## ⑥ OL indicators (1–8)

These indicators light when the signal fed to the A/D converter for the channel (post-pad and post **TRIM**) outputs a signal which is more than  $-3$  dB, relative to the digital “full-scale” level.

## ⑦ TRIM controls (1–8)

The **TRIM** controls adjust the level of the signal before it is passed to the A/D converter. They work in a similar way to **TRIM** controls on a mixing console; turn clockwise to increase the gain, counter-clockwise to reduce it.

The **TRIM** controls provide 42 dB of gain control.

## ⑧ PAD switches (1–8)

When engaged, these **PAD** switches provide 22 dB of attenuation to the corresponding channel. Use them in conjunction with the **TRIM** controls to input line-level sources through the MA-AD8.

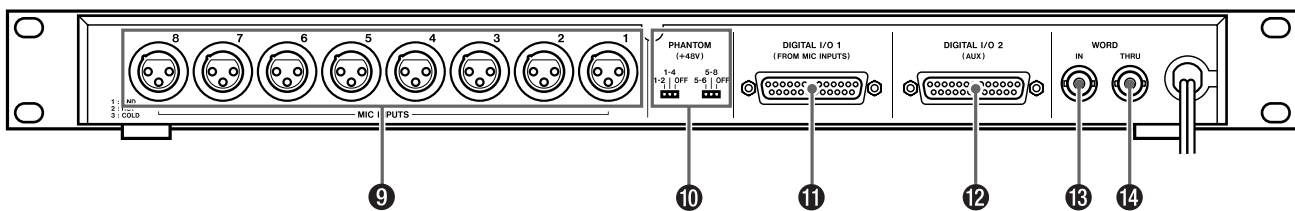

## 1.2 Rear panel

### ⑨ MIC INPUTS (1–8)

These balanced XLR-type input connectors are wired:

1	GND
2	Hot (+)
3	Cold (-)

### ⑩ PHANTOM (+48V) switches

These switches control the +48 V phantom power supply to the **MIC INPUT**s. Each switch controls the phantom power supplied to a group of four inputs—1 through 4, and 5 through 8.

They each have three positions, which allow the first two inputs of the group (**1–2** and **5–6**) to be supplied with phantom power (phantom power to the other two inputs of the group will be turned off), to all inputs of the group, or off for all inputs in the group.

Note that it is not possible to supply phantom power only to the second pair of inputs in a group.

To avoid damage to monitor speakers, etc., turn down the level of all monitoring equipment before operating these switches.

## WARNING

*Do not connect unbalanced signal sources (dynamic microphones, instruments, etc.) to a **MIC INPUT** connector with phantom power supplied to that connector. This will result in possible damage to the signal source, and to the MA-AD8.*

**MICROPHONE CABLES AND MICROPHONES CONNECTION:** TO PREVENT HAZARD OR DAMAGE, ENSURE THAT ONLY MICROPHONE CABLES AND MICROPHONES DESIGNED TO THE IEC 268-15A STANDARD ARE CONNECTED.

**CONNEXIONS DES MICROPHONES ET DE LEURS CABLES:** POUR EVITER TOUT ENDOMMAGEMENT, S'ASSURER DE BRANCHER UNIQUEMENT DES MICROPHONES ET DES CABLES DE MICROPHONES CONÇUS SELON LA NORME IEC 268-15A.

# MA-AD8 Digital Mic Amplifier

## ⑪ DIGITAL I/O1 (FROM MIC INPUTS)

This connector is typically used to connect a TDIF-1-equipped mixing console.

The digital audio signals received at this connector will always be passed through to the **DIGITAL I/O2 (AUX)** ⑫ connector. This cannot be changed.

The digital audio signals output from this connector are selected from either the MA-AD8 A/D converters or from the signals received at the **DIGITAL I/O2 (AUX)** ⑫ connector, depending on the settings of the **INPUT** switches ⑤.

### WARNING

*Note that you should always use genuine TASCAM cables, or cables which have been approved for use with TDIF-1 interfaces by TASCAM.*

*Although these cables appear similar to certain types of computer cables and use similar connectors, the cables themselves are very different, and the different electrical characteristics of the cables can cause damage to the equipment connected with the wrong cables.*

*If the use of cables other than TASCAM cables causes or results in damage, the warranty is voided.*

## ⑫ DIGITAL I/O2 (AUX)

This connector is typically used to connect a TDIF-1-equipped multitrack recorder, such as a DTRS recorder.

The digital audio signals output from this connector will always be the digital audio signals received from the **DIGITAL I/O1 (FROM MIC INPUTS)** ⑪ connector. This cannot be changed.

The digital audio signals received at this connector may be used as sources for the **DIGITAL I/O1 (FROM MIC INPUTS)** ⑪ connector, depending on the setting of the **INPUT** switches ⑤.

## ⑬ WORD IN

An external word clock may be connected to this BNC connector (75Ω), and used as the word synchronization for the MA-AD8, selected with the **CLOCK** switch ③.

## ⑭ WORD THRU

This BNC connector echoes the clock signal received at the **WORD IN** ⑬ connector. If no device is con-

nected here, the word clock chain is automatically terminated.

## 1.3 A practical example of using the MA-AD8

Since the MA-AD8 provides a good deal of flexibility, it may be useful to review a typical situation in which it may be used.

### 1.3.1 Recording multitrack tracks

In a multitrack situation, the initial tracks may be laid down using the following setup:

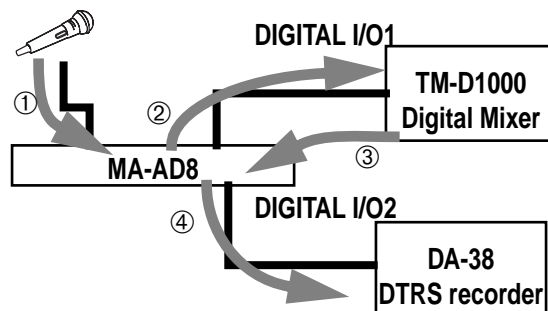

In this example, all the **INPUT** switches ⑤ on the MA-AD8 are set to accept signals from the internal A/D converters (i.e. from the **MIC** sources) ①. The signal then goes from the **DIGITAL I/O1** port into the mixer ②, which can now use channels 9 through 16 as additional inputs from analog sources. The group busses are routed back through the TDIF-1 connector ③ and are passed through the MA-AD8's **DIGITAL I/O2** connector to the DTRS recorder ④.

The word clock originates in the TM-D1000, and the **CLOCK** switch on the MA-AD8 is therefore set to **TDIF-1**, and the **STATUS** switch to **D I/O1**. This clock is passed through the TDIF-1 connection to the DTRS recorder.

### 1.3.2 Mixdown

When mixing down, the situation is simplified as shown below:

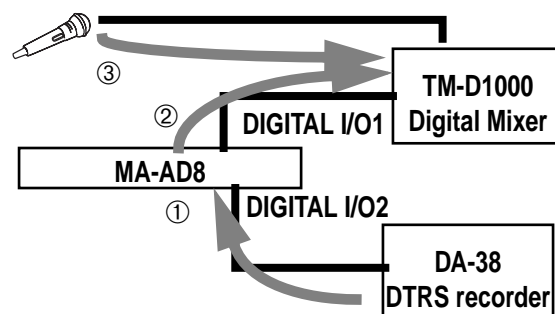

The **INPUT** switches ⑤ of the MA-AD8 are set to the **TDIF-1** setting and the tape tracks are replayed into

# MA-AD8 Digital Mic Amplifier

the **DIGITAL I/O2** port ①. They are then passed straight through to the **DIGITAL I/O2** port connected to the mixer ②.

If necessary, other analog inputs (e.g. MIDI-sequenced instruments) may be played through channels 1 through 8 of the mixer simultaneously with the replayed digital tracks from the DTRS recorder.

The advantage of using the MA-AD8 in this situation is that the digital audio cabling is permanent—no disconnection and re-connection of cables needs to be done, and the MA-AD8's front panel switches provide convenient re-routing facilities.

## 1.4 Specifications

MIC INPUTs (1–8)	XLR-type, balanced inputs
Input impedance	2.4 k $\Omega$
OL (overload) indicator 1–8	Lights at 3 dB below digital full-scale level
TRIM range	42 dB
PAD attenuation	22 dB
Input level (TRIM at max)	–56 dBu
Input level (TRIM at min)	–14 dBu
S/N ratio (IHF-A, 150 $\Omega$ terminated)	>86 dB (TRIM at maximum), >94 dB (TRIM at minimum)
Crosstalk between adjacent channels	>80 dB @ 10 kHz

Frequency response	20 Hz to 22 kHz +0.5/–1.0 dB (Fs=48 kHz)
T.H.D. (@ 1 kHz)	<0.03% (TRIM at minimum, nominal level)
Digital output format	TDIF-1
Sampling frequency	44.1 kHz, 48 kHz, $\pm$ 6%
A/D resolution	20 bit
Clock source	D I/O1, D I/O2, external word clock
LOCKED indicator	Lights when valid clock source received at selected input
WORD CLOCK IN	75 $\Omega$
WORD CLOCK THRU	75 $\Omega$ (auto terminating)
Dimensions (w x h x d)	482 x 48 x 210 (mm) 19 x 1.9 x 8.3 (in)
Weight	2.2 kg (5.5 lbs)
Power supply	120 V (USA/Canada) 230 V (Europe) 240 V (Australia)
Power consumption	10W
Supplied accessories	Rack mounting kit

### 1.4.1 Dimensional drawing

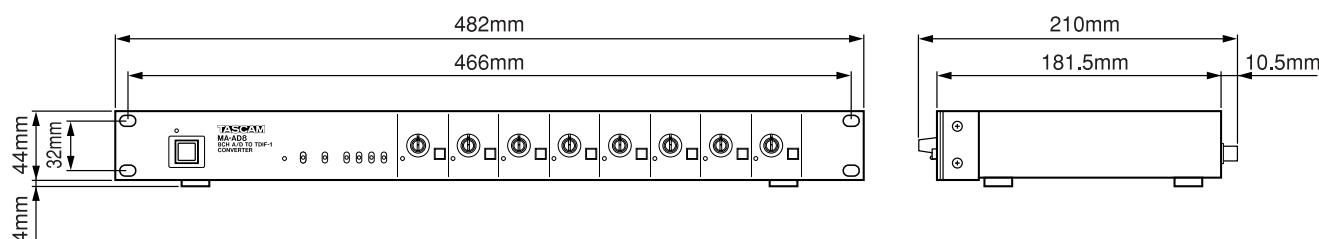

# MA-AD8 Digital Mic Amplifier

## 1.4.2 Block diagram

MA-AD8 BLOCK DIAGRAM

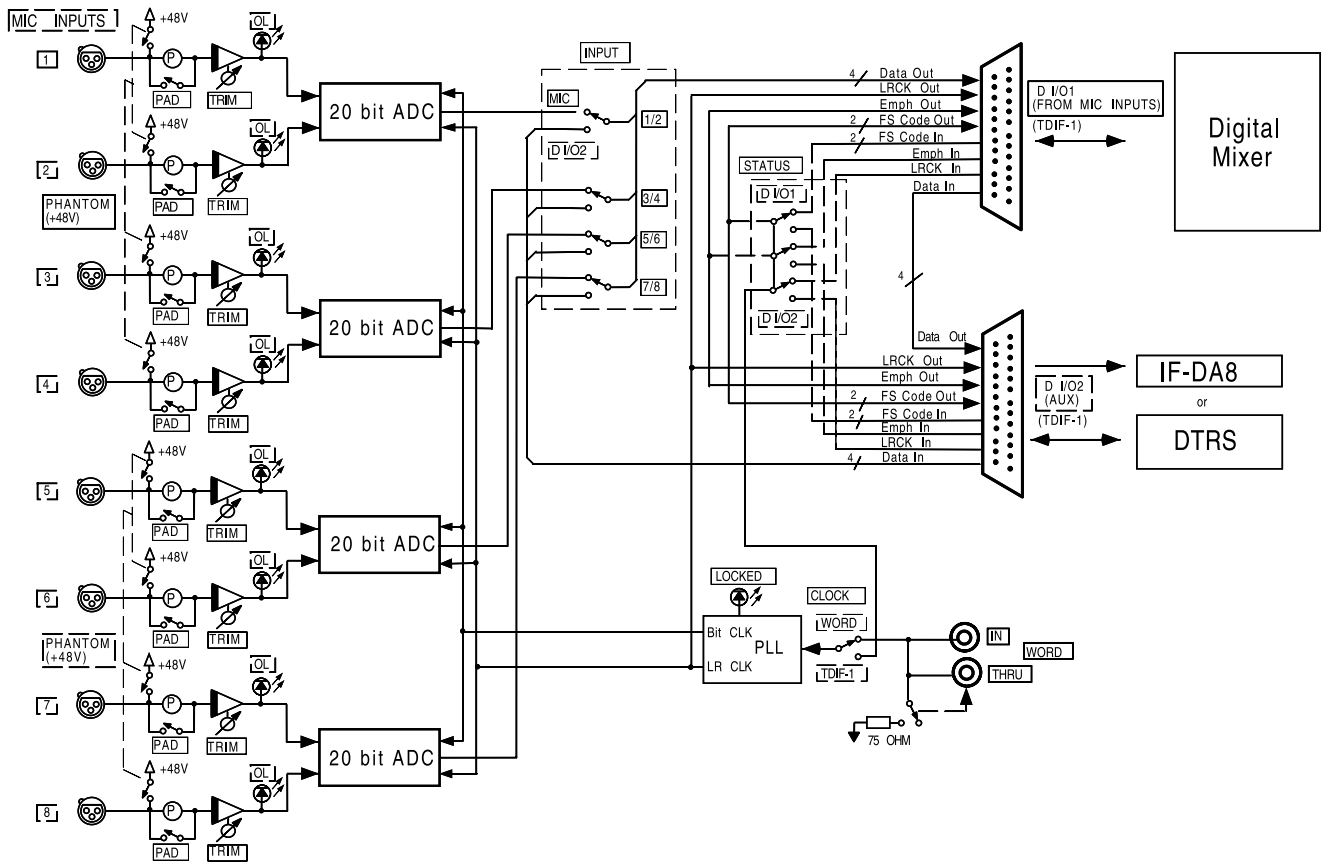

## TEAC CORPORATION

Phone: (0422) 52-5082

3-7-3, Nakacho, Musashino-shi, Tokyo 180-8550, Japan

### TEAC AMERICA, INC.

Phone: (213) 726-0303

7733 Telegraph Road, Montebello, California 90640

### TEAC CANADA LTD.

Phone: 905-890-8008 Facsimile: 905-890-9888

5939 Wallace Street, Mississauga, Ontario L4Z 1Z8, Canada

### TEAC MEXICO, S.A. De C.V.

Phone: 5-658-1943

Privada De Corina, No.18, Colonia Del Carmen Coyoacan, Mexico DF 04100

### TEAC UK LIMITED

Phone: 01923-819699

5 Marlin House, Marlins Meadow, The Croxley Centre, Watford, Herts. WD1 8YA, U.K.

### TEAC DEUTSCHLAND GmbH

Phone: 0611-71580

Bahnstrasse 12, 65205 Wiesbaden-Erbenheim, Germany

### TEAC FRANCE S. A.

Phone: 01.42.37.01.02

17 Rue Alexis-de-Tocqueville, CE 005 92182 Antony Cedex, France

### TEAC BELGIUM NV/SA

Phone: 0031-30-6048115

P.A. TEAC Nederland BV, Perkinsbaan 11a, 3439 ND Nieuwegein, Netherlands

### TEAC NEDERLAND BV

Phone: 030-6030229

Perkinsbaan 11a, 3439 ND Nieuwegein, Netherlands

### TEAC AUSTRALIA PTY.,LTD. A.C.N. 005 408 462

Phone: (03) 9644-2442

106 Bay Street, Port Melbourne, Victoria 3207, Australia

### TEAC ITALIANA S.p.A.

Phone: 02-66010500

Via C. Cantù 11, 20092 Cinisello Balsamo, Milano, Italy